

Nockenwellen-Steuerventil-Einsätze für VAG 1.8 / 2.0 TFSi / TSI



WERKZEUGE

Nr.	Bezeichnung	zu verwenden wie OEM
1	Spezialeinsatz für Nockenwellen-Steuerventile	T10352/1
2	Spezialeinsatz für Nockenwellen-Steuerventile	T10352
3	Spezialeinsatz für Nockenwellen-Steuerventile	T10352/2

ALLGEMEINE HINWEISE

Dieser Werkzeugsatz besteht aus 3 Spezialeinsätzen mit 10 (3/8) Antrieb. Die Werkzeuge dienen der Demontage/Montage des 4-/3-Wege Zentralventils für die Nockenwellenverstellung an 1,8 & 2,0 Liter 4-Zylinder-Einspritz- / Direkteinspritzmotoren mit Steuerkette in Modellen von Audi, Volkswagen, Seat und Skoda.

SICHERHEITSHINWEISE

- Vorsicht bei Arbeiten an heißen Motoren. Es besteht Verbrennungsgefahr!
- Vorsicht bei Arbeiten an laufenden Motoren. Weite Kleidung, Werkzeuge und andere Gegenstände können von drehenden Motorteilen erfasst werden und zu schweren Verletzungen führen.
- Entfernen Sie den Zündschlüssel vor Arbeitsbeginn, so verhindern Sie ein versehentliches Starten des Motors.
- **Diese Anleitung dient als Kurzinformation und ersetzt keinesfalls ein Werkstatthandbuch.** Verwenden Sie immer fahrzeugspezifische Serviceliteratur, aus dieser entnehmen Sie bitte technische Angaben wie Drehmomentwerte, Hinweise zur Demontage / Montage usw.
- Nach erfolgter Reparatur bzw. vor dem Starten den Motor min. 2 Umdrehungen von Hand drehen und die Steuerzeiten erneut überprüfen.



FAHRZEUGLISTE

Hersteller	Modell	Typ	Motorcode	Jahr
AUDI	A3	1.8 / 2.0 TFSi / TSI	BYT / BZB	2007-2013
			CABA / CABB	
			CABD / CAWB	
			CBFA / CCTA	
			CCZA / CCZB	
			CCZC / CDHA	
			CDHB / CDNB	
			CDNC / CDND	
	A4	1.8 / 2.0 TFSi / TSI	CFKA / CGYA	2007-2013
A5	1.8 / 2.0 TFSi / TSI	CCZA / CCZB	2007-2013	
Q5	1.8 / 2.0 TFSi / TSI	CCZC / CCZD	2007-2013	
TT	1.8 / 2.0 TFSi / TSI	CDA A / CDAB	2008-2013	
SEAT	Altea	1.8 / 2.0 TFSi / TSI	BYT / BZB	2009-2013
	Leon	1.8 / 2.0 TFSi / TSI	CABA / CABB	2007-2013
	Toledo	1.8 / 2.0 TFSi / TSI	CABD / CAWB	2007-2013
	Exeo	1.8 / 2.0 TFSi / TSI	CBFA / CCTA	2010-2013
SKODA	Octavia II	1.8 / 2.0 TFSi / TSI	CCZA / CCZB	2007-2013
	Superb II	1.8 / 2.0 TFSi / TSI	CCZC / CDHA	2008-2013
	Yeti	1.8 / 2.0 TFSi / TSI	CDHB / CDNB	2009-2013
VOLKSWAGEN	Eos	1.8 / 2.0 TFSi / TSI	CDNC / CDND	2008-2013
	Golf	1.8 / 2.0 TFSi / TSI	CFKA / CGYA	2007-2013
	Jetta	1.8 / 2.0 TFSi / TSI	CCZA / CCZB	2007-2011
	Passat	1.8 / 2.0 TFSi / TSI	CCZC / CCZD	2007-2013
	Scirocco	1.8 / 2.0 TFSi / TSI	CDA A / CDAB	2008-2013
	Sharan	1.8 / 2.0 TFSi / TSI		2011-2013
	Tiguan	1.8 / 2.0 TFSi / TSI		2007-2013

ANWENDUNG

Motorabdeckung, Steuerventil-Steckverbindungen und oberen Steuergehäusedeckel entfernen.

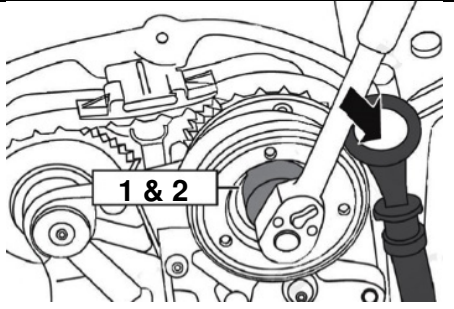
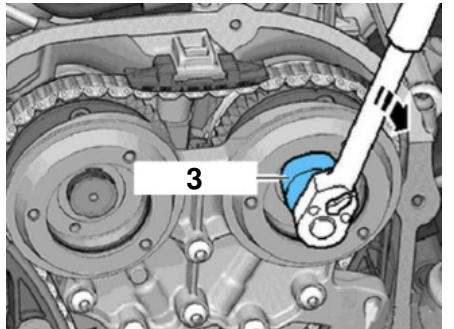
<p>Nockenwelle in Servicestellung drehen.</p>	
<p>ACHTUNG Die Steuerventile haben ein Linksgewinde. Zur Demontage des linken und rechten Steuerventils das Werkzeug in Pfeilrichtung drehen.</p>	

Camshaft Control Valve Sockets for VAG 1.8 / 2.0 TFSi / TSI

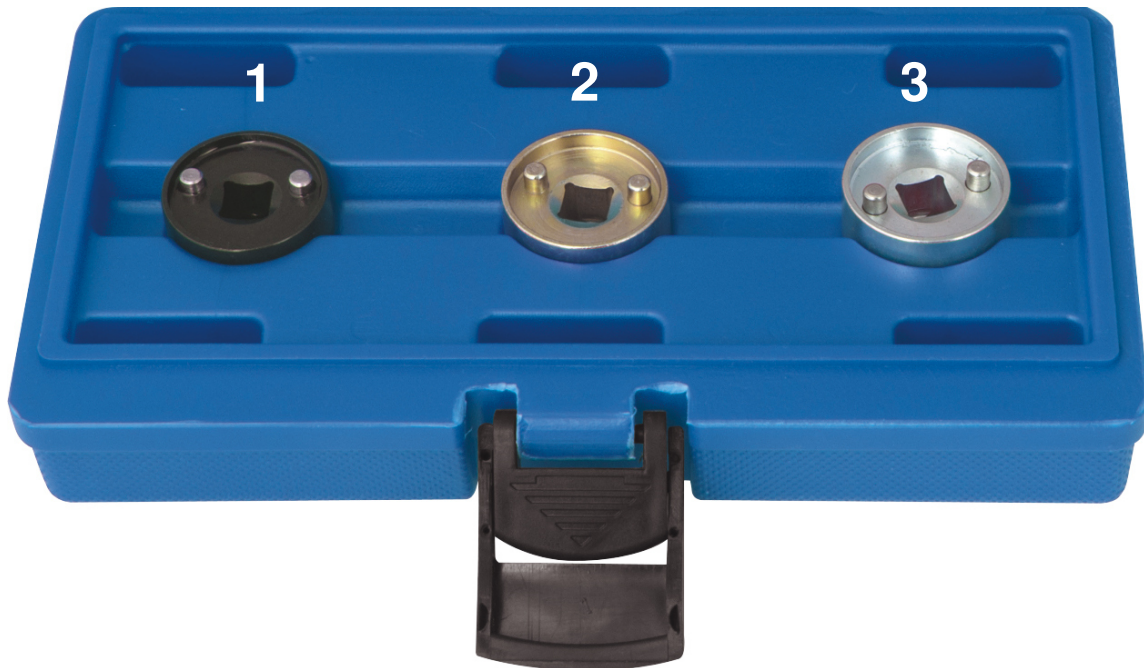

TOOLS

No.	Description	to be used as OEM
1	Special Socket for Camshaft Control Valve	T10352/1
2	Special Socket for Camshaft Control Valve	T10352
3	Special Socket for Camshaft Control Valve	T10352/2

GENERAL INFORMATIONS

This tool set includes 3 special sockets with 3/8" drive. The tools are made for disassembling / assembling of the 4/3-way central valve for camshaft adjustment on 1.8 & 2.0 liter 4-cylinder injection / direct injection engines with timing chain in models from Audi, Volkswagen, Seat and Skoda.

SAFETY ADVICE

- Be careful when working on hot engines – risk of burn!
- Be careful when working on running engines. Loose clothes, tools and other things can be caught up in revolving parts which may lead to serious injuries.



- Remove the ignition key before repair so that the engine will not start unintentionally.



- ***This manual is just brief information and will not replace a workshop manual.*** Always consult specific service literature for information about torques, assemblies and disassemblies etc.



- After any successful maintenance and before starting the engine, you should rotate the engine for two turns manually to check the new control time.



VEHICLE LIST

Manufacturer	Model	Type	Engine Code	Year
AUDI	A3	1.8 / 2.0 TFSi / TSI	BYT / BZB	2007-2013
			CABA / CABB	
			CABD / CAWB	
			CBFA / CCTA	
			CCZA / CCZB	
			CCZC / CDHA	
			CDHB / CDNB	
			CDNC / CDND	
	A4	1.8 / 2.0 TFSi / TSI	CFKA / CGYA	2007-2013
A5	1.8 / 2.0 TFSi / TSI	CCZA / CCZB	2007-2013	
Q5	1.8 / 2.0 TFSi / TSI	CCZC / CCZD	2007-2013	
TT	1.8 / 2.0 TFSi / TSI	CDA A / CDAB	2008-2013	
SEAT	Altea	1.8 / 2.0 TFSi / TSI	BYT / BZB	2009-2013
	Leon	1.8 / 2.0 TFSi / TSI	CABA / CABB	2007-2013
	Toledo	1.8 / 2.0 TFSi / TSI	CABD / CAWB	2007-2013
	Exeo	1.8 / 2.0 TFSi / TSI	CBFA / CCTA	2010-2013
SKODA	Octavia II	1.8 / 2.0 TFSi / TSI	CCZA / CCZB	2007-2013
	Superb II	1.8 / 2.0 TFSi / TSI	CCZC / CDHA	2008-2013
	Yeti	1.8 / 2.0 TFSi / TSI	CDHB / CDNB	2009-2013
VOLKSWAGEN	Eos	1.8 / 2.0 TFSi / TSI	CDNC / CDND	2008-2013
	Golf	1.8 / 2.0 TFSi / TSI	CFKA / CGYA	2007-2013
	Jetta	1.8 / 2.0 TFSi / TSI	CCZA / CCZB	2007-2011
	Passat	1.8 / 2.0 TFSi / TSI	CCZC / CCZD	2007-2013
	Scirocco	1.8 / 2.0 TFSi / TSI	CDA A / CDAB	2008-2013
	Sharan	1.8 / 2.0 TFSi / TSI		2011-2013
	Tiguan	1.8 / 2.0 TFSi / TSI		2007-2013

APPLICATION

Remove engine cover, control valve connectors and upper timing cover.

Rotate the camshaft in the service position.

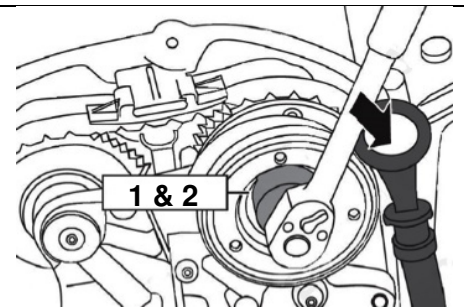

CAUTION: The control valves have a left-hand thread.

To remove the left and right control valve, rotate the tool in direction of arrow.

