

Motor-Einstellsatz für Mini N12 & PSA Motoren

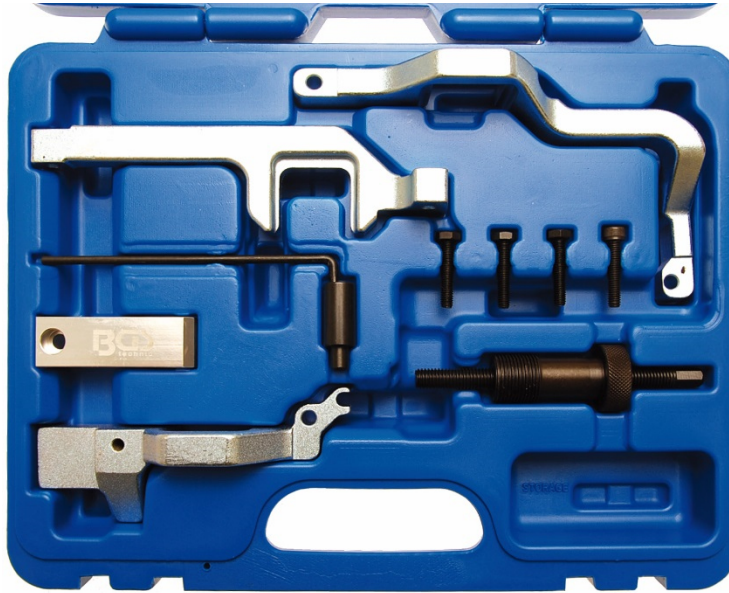

ALLGEMEIN

Dieser Satz enthält wichtige Werkzeuge die benötigt werden beim Erneuern der Zylinderkopfdichtung, der Steuerkette und Überprüfen der Motorsteuerzeiten am Mini R55 und R56 mit Motorcode N12 und PSA Motoren. Die Werkzeuge ermöglichen das Arretieren und Einstellen der Kurbelwelle, Nockenwelle und Kettenspanner.

ANWENDUNGEN

FAHRZEUG	MOTORCODE
BMW Mini One Cooper R55-56 Cooper HB	Motorcode N12
Citroen C4 (08-09) C4 Picasso (08-09)	1,4 VTi (Valvetronic) EP3(8FS) (Valvetronic) EP6(5FW), 1.6THP (DI)
Peugeot 207 (06-09) 207CC (07-09) 308 (01-09)	EP6DT(5FX) EP6DTS(5FY)

SICHERHEITSHINWEISE

- Vorsicht bei Arbeiten an heißen Motoren, es besteht Verbrennungsgefahr!
- Vorsicht bei Arbeiten an laufenden Motoren. Lose Kleidung, Werkzeuge und andere Gegenstände können von drehenden Teilen erfasst werden und zu schweren Verletzungen führen.
- Entfernen Sie vor der Reparatur den Zündschlüssel, so verhindern Sie ein versehentliches Starten des Motors.
- **Diese Anleitung dient als Kurzinformation und ersetzt keinesfalls ein Werkstatthandbuch.** Verwenden Sie immer eine fahrzeugspezifische Serviceliteratur. Aus dieser entnehmen Sie bitte technische Angaben wie Drehmomentwerte, Hinweise zur Demontage / Montage usw..
- Nach erfolgter Reparatur bzw. vor dem Starten den Motor min. 2 Umdrehungen von Hand drehen und die Steuerzeiten erneut überprüfen.

WERKZEUGE

Kurbelwellenfixierer

zu verwenden wie OEM 119590

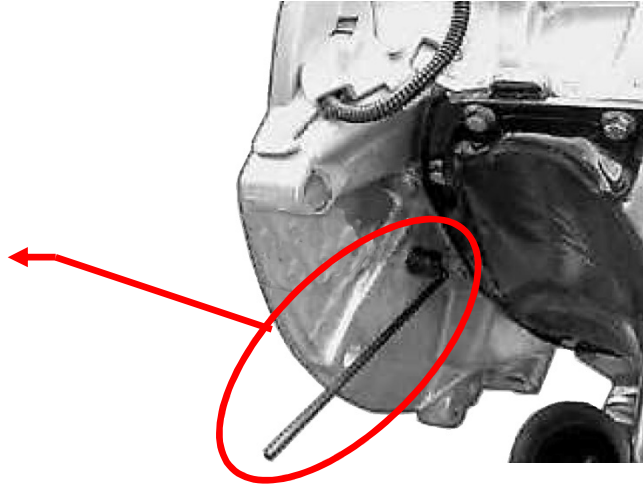

Nockenwellenfixierer

zu verwenden wie OEM 119540

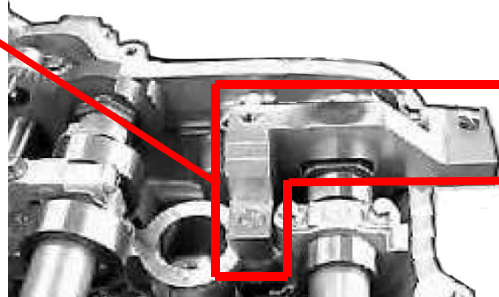
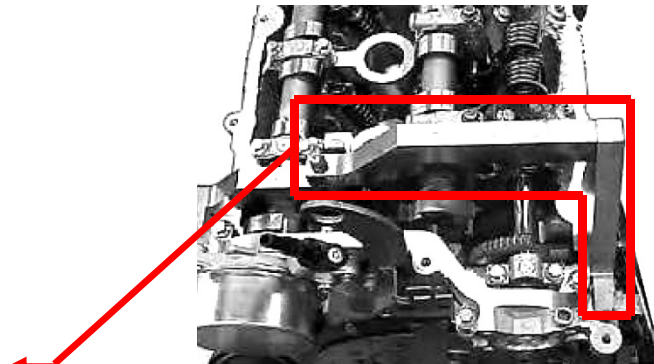

Kettenspanner

zu verwenden wie OEM 119340

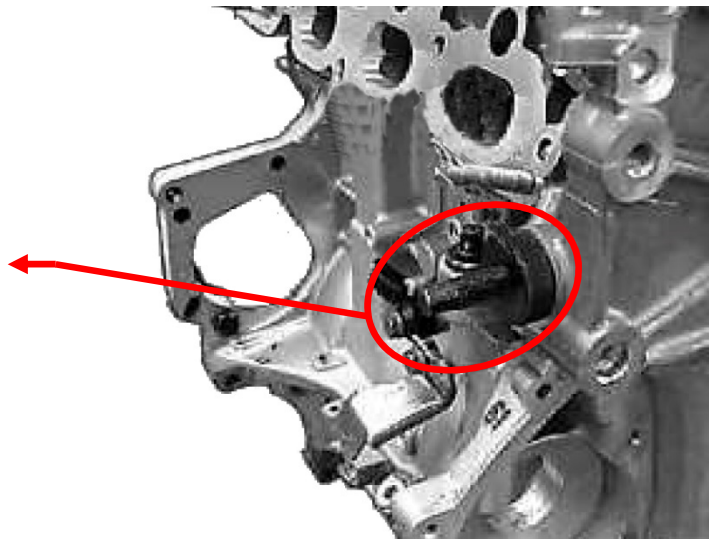

Timing Tool Set for Mini N12 & PSA Engines

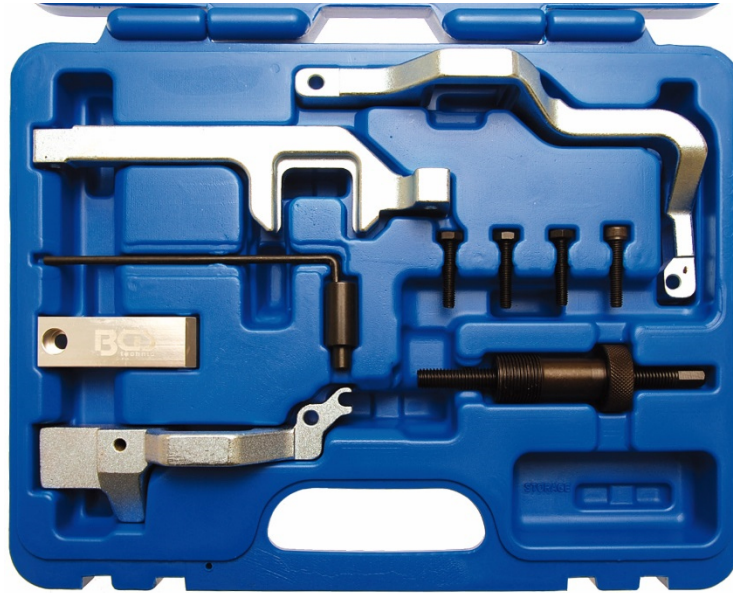

GENERAL

This tool kit contains essential tools that are required when replacing the cylinder head gasket, timing chain and checking the engine timing on Mini R55 and R56 with engine code N12 and on PSA engines. The tools allow you to lock and set the crankshaft, camshaft and chain tensioner.

APPLICATIONS

VEHICLE	ENGINE CODE
BMW Mini One Cooper R55-56 Cooper HB	N12
Citroen C4 (08-09) C4 Picasso (08-09)	1,4 VTi (Valvetronic) EP3(8FS) (Valvetronic) EP6(5FW), 1.6THP (DI)
Peugeot 207 (06-09) 207CC (07-09) 308 (01-09)	EP6DT(5FX) EP6DTS(5FY)

SAFETY ADVICE

- Be careful when working on hot engines – risk of burn!
- Be careful when working on running engines. Loose clothes, tools and other things can be caught up in revolving parts which may lead to serious injuries.
- Remove the ignition key before repair so that the engine will not start unintentionally.
- ***This manual is just brief information and will not replace a garage handbook. Always consult specific service literature for information about torques, assemblies and disassemblies etc.***
- After any successful maintenance and before starting the engine, you should rotate the engine for two turns manually to check the new control time.

TOOLS

Crankshaft Locking Tool
to be used as OEM 119590

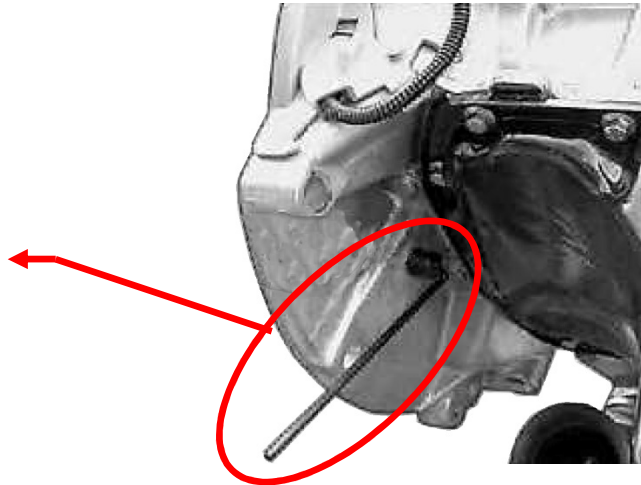

Camshaft Locking Tool
to be used as OEM 119540

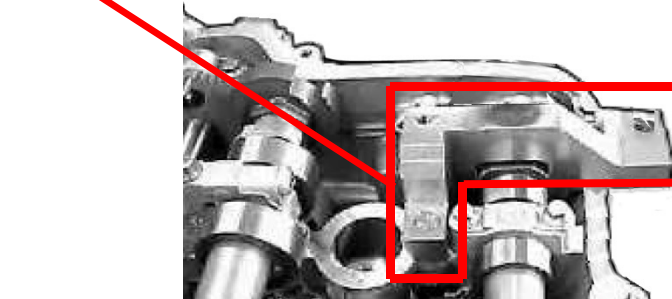
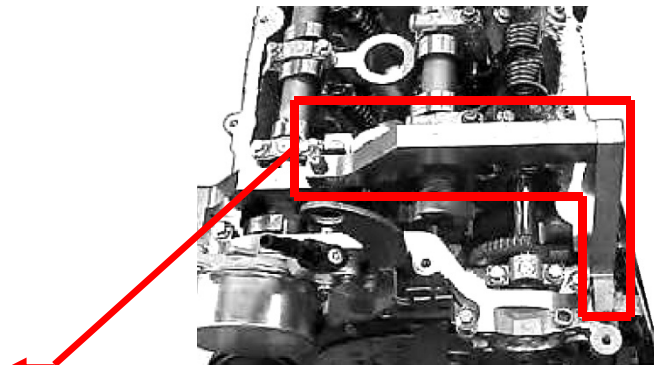

Chain Tensioner
to be used as OEM 119340

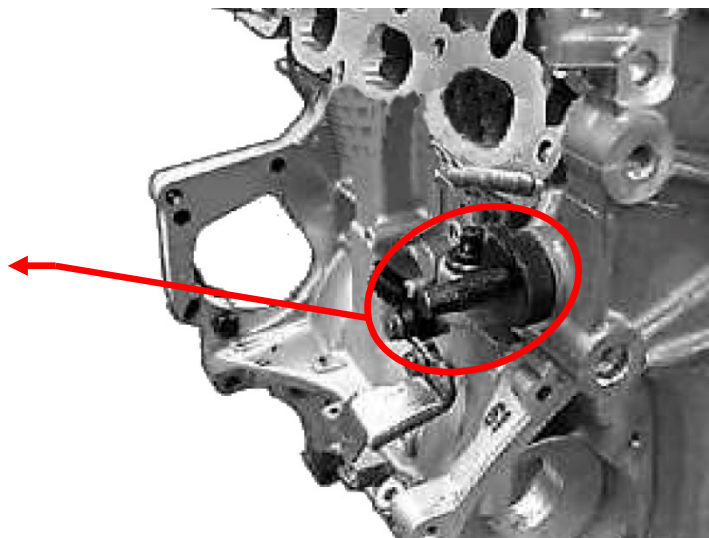

Set messa in fase per Mini N12 & motori PSA

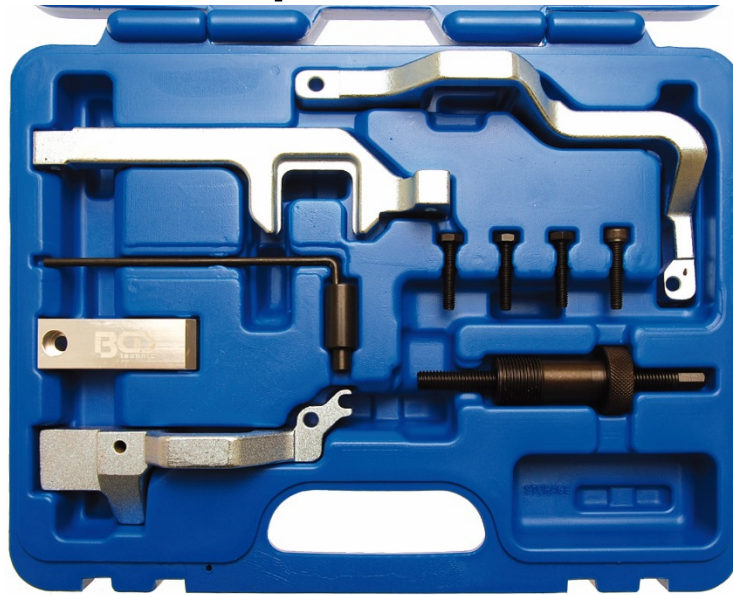

GENERALE

Questo kit contiene attrezzi essenziali che sono richiesti quando si sostituiscono le guarnizioni della testa del cilindro, la fasatura della catena e il controllo della fasatura del motore su Mini R55 and R56 con codice motore N12 e su motori PSA. Gli attrezzi ti permettono di chiudere e impostare l'albero motore, l'albero a camme e il tendicatena.

APPLICAZIONE

VEICOLO	CODICE MOTORE
BMW Mini One Cooper R55-56 Cooper HB	N12
Citroen C4 (08-09) C4 Picasso (08-09)	1,4 VTi (Valvetronic) EP3(8FS) (Valvetronic) EP6(5FW), 1.6THP (DI)
Peugeot 207 (06-09) 207CC (07-09) 308 (01-09)	EP6DT(5FX) EP6DTS(5FY)

CONSIGLI DI SICUREZZA

- Fare attenzione quando si lavora su motori caldi – rischio di bruciatura!
- Fare attenzione quando si lavora su motori accesi. Vestiti larghi, attrezzi e altre cose possono essere prese nelle parti girevoli che possono causare gravi danni.
- Rimuovere la chiave di accensione prima di riparare cosicché il motore non partirà involontariamente.
- **Questo manuale è solo di breve informazione e non sostituirà un manuale da autofficina.** Consultare sempre libretti di servizio specifici per informazione sulla torsione, assemblaggio e disassemblaggio ecc.
- Dopo ogni manutenzione riuscita e prima di avviare il motore, roteare il motore con due giri manualmente per controllare il nuovo tempo di controllo.

ATTREZZI

Attrezzo di chiusura dell'albero motore

Deve essere usato con OEM
119590

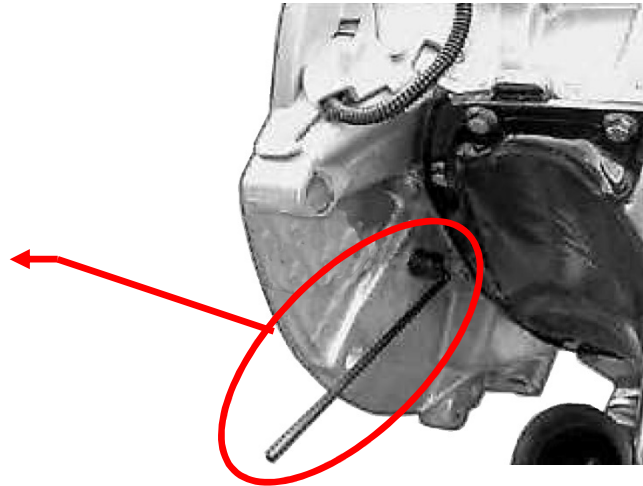

Attrezzo di chiusura dell'albero a camme

Deve essere usato come OEM
119540

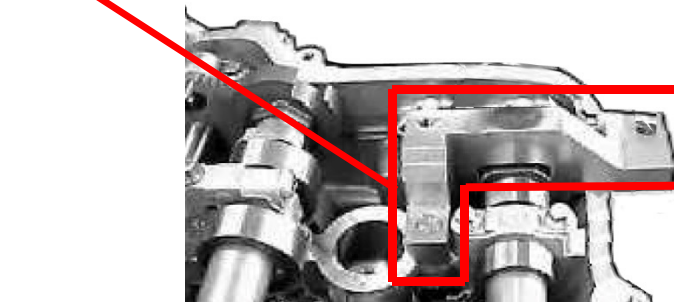
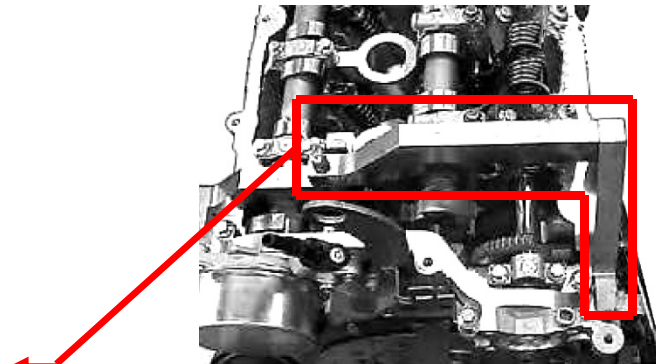

Tendicatena

Deve essere usato con OEM
119340

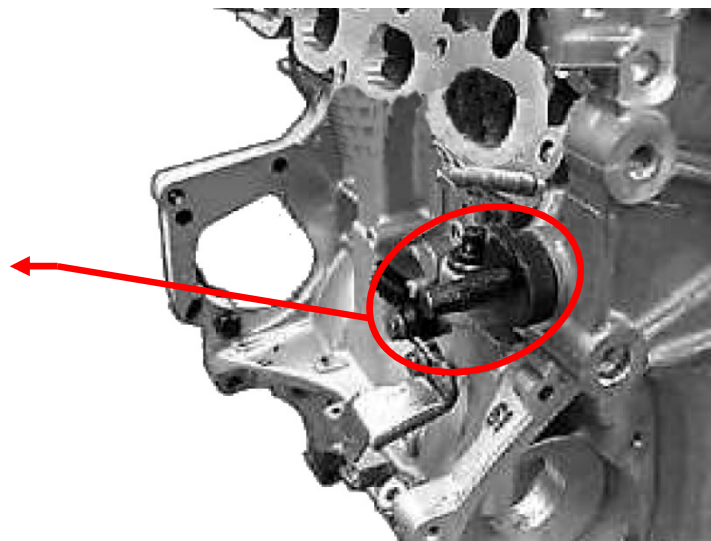

Kit de sincronización para motores Mini N12 & PSA

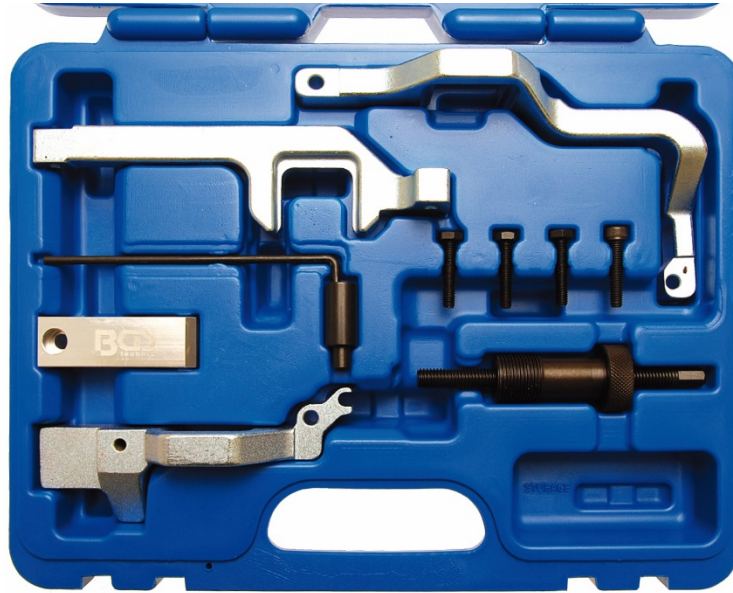

GENERAL

Este kit contiene herramientas esenciales que son requeridas para cambiar la junta del cilindro, cadena, y comprobar la sincronización del motor en Mini R55 y R56 con motores de código N12 y PSA. Las herramientas permiten, bloquear y fijar el cigüeñal, el árbol de levas y la cadena de tensión.

APLICACIONES

VEHICULO	CODIGO DE MOTOR
BMW Mini One Cooper R55-56 Cooper HB	N12
Citroen C4 (08-09) C4 Picasso (08-09)	1,4 VTi (Valvetronic) EP3(8FS) (Valvetronic) EP6(5FW), 1.6THP (DI)
Peugeot 207 (06-09) 207CC (07-09) 308 (01-09)	EP6DT(5FX) EP6DTS(5FY)

AVISOS DE SEGURIDAD

- Tenga cuidado cuando trabaje con motores calientes – riesgo de quemaduras.
- Cuidado cuando trabaje con motores encendidos. La ropa floja, herramienta y otros objetos pueden engancharse en las partes móviles y pueden causar serias lesiones.
- Quite la llave del contacto para evitar cualquier encendido del motor accidental..
- **Estas instrucciones sirven como una descripción y no sustituyen al manual técnico.**
Refiérase siempre al libro técnico específico de cada vehículo. Por favor, obtenga de este libro los datos técnicos.
- Después de un mantenimiento satisfactorio y antes de encender el motor, debe girar el motor unas dos veces manualmente para comprobar la sincronización.

HERRAMIENTAS

Herramienta bloqueo cigüeñal
Para usar como OEM 119590

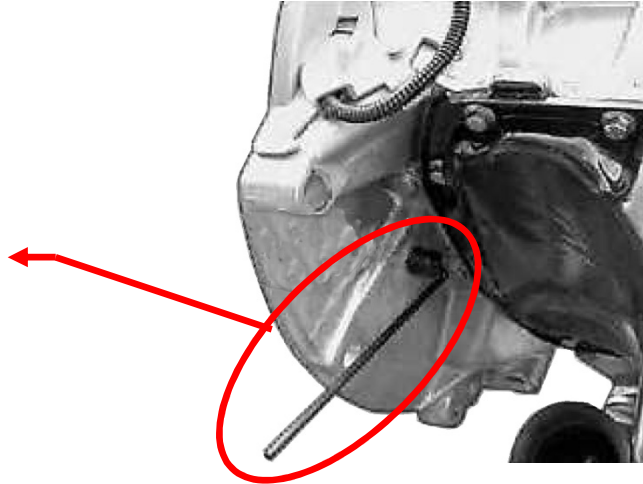

Herramienta bloqueo árbol de levas
Para usar como OEM 119540

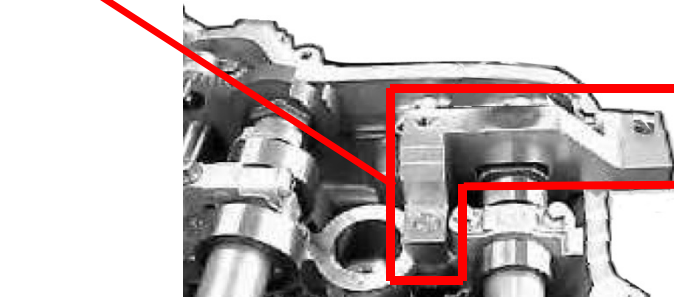
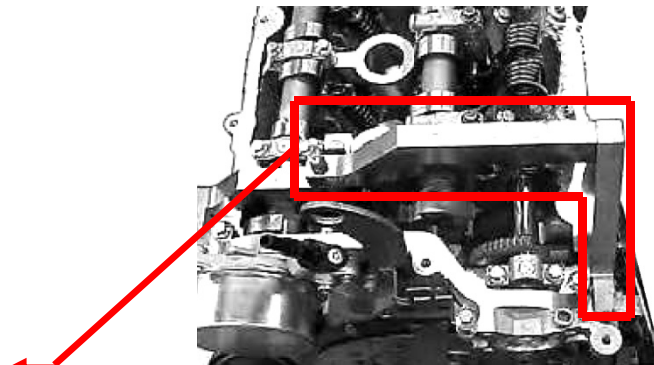

Cadena de tensión
Para usar como OEM 119340

