

Technical information

Read before installation

40-1290FK vs 40-1149FK

Kit Chain + Gear



40-1290FK

OEM: 130C10990R

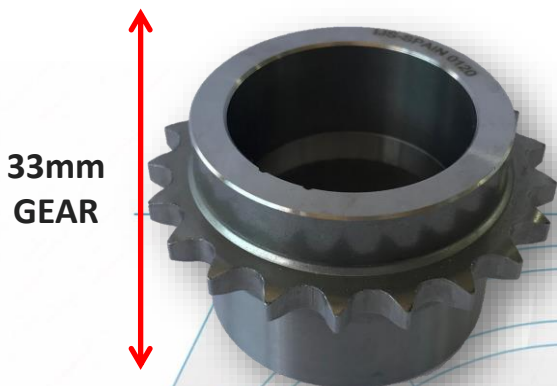

40-1149FK

OEM: 130C18929R

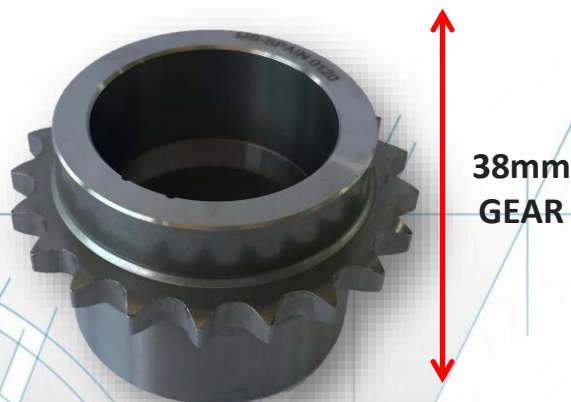

Check that the crankshaft gear you removed matches the equipment in this kit. If an incorrect crankshaft gear is installed, the crankshaft pulley will be misaligned preventing proper transmission of the auxiliary belts.

ES

Información técnica

Leer antes de la instalación

Compruebe que el engranaje del cigüeñal que ha desmontado coincide con el de este kit. Si se instala un engranaje incorrecto del cigüeñal, la polea del cigüeñal estará desalineada impidiendo una correcta transmisión de las correas auxiliares.

FR

Information technique

A lire avant l'installation

Vérifiez que le pignon de vilebrequin que vous avez retiré correspond à celui de ce kit. Si un pignon de vilebrequin incorrect est installé, la poulie de vilebrequin sera mal alignée empêchant une transmission correcte des courroies auxiliaires.

PT

Informação técnica

Leia antes da instalação

Verifique se a engrenagem do virabrequim removida corresponde à deste kit. Se uma engrenagem incorreta do virabrequim estiver instalada, a polia do virabrequim ficará desalinhada, impedindo a transmissão adequada das correias auxiliares.

IT

Informazioni tecniche

Leggere prima dell'installazione

Controllare che l'ingranaggio dell'albero motore che si è rimosso corrisponda a quello di questo kit. Se è installato un ingranaggio dell'albero a gomiti errato, la puleggia dell'albero a gomiti sarà disallineata impedendo la corretta trasmissione delle cinghie ausiliarie.

RU

Техническая информация

Прочитайте перед установкой

Убедитесь, что снятая шестерня коленчатого вала соответствует этому комплекту. Если установлена неправильная шестерня коленвала, шкив коленвала будет смещен, что помешает правильной передаче вспомогательных ремней.

