

Einbauanleitung Elektrosatz
Anhängervorrichtung mit 12-N Steckdose
lt. DIN/ISO Norm 1724

Instructions de montage du faisceau
électrique pour crochet d'attelage
conforme à la norme
DIN/ISO 1724 prise 12-N

Fitting instructions electric wiringkit
towbar with 12-N socket up to
DIN/ISO norm 1724

Montage-handleiding elektrokabelset voor
trekhaak met 12-N contactdoos
vlgs. DIN/ISO norm 1724

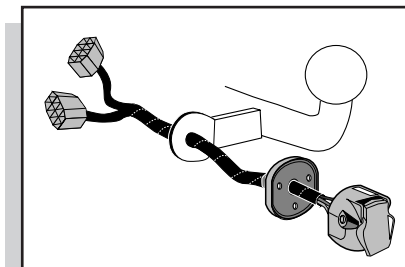

OPEL ASTRA STATION 1998-

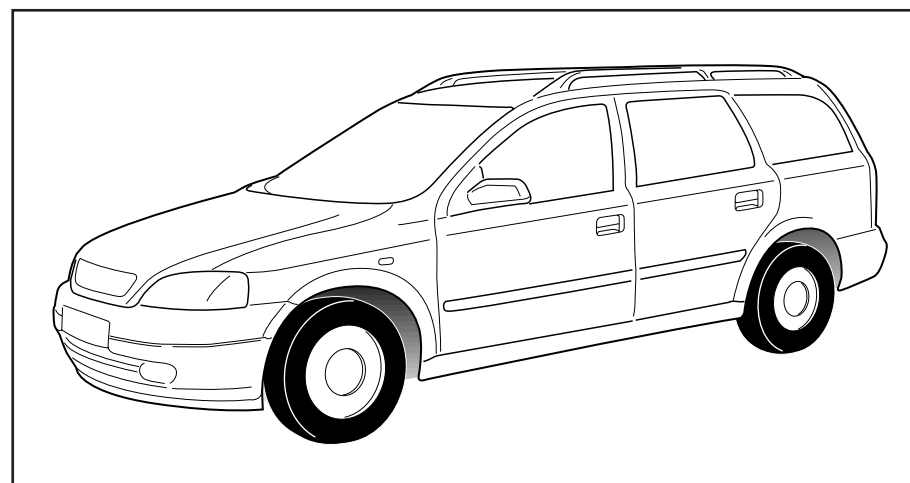

Bestel Nr.: OP-015-BL

1

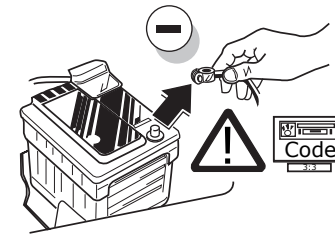

2

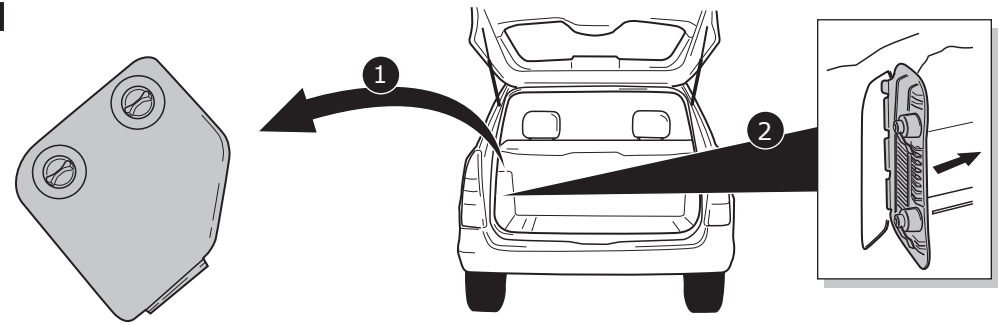

3

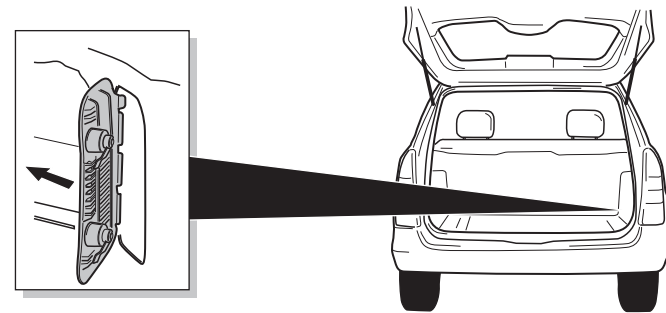

4

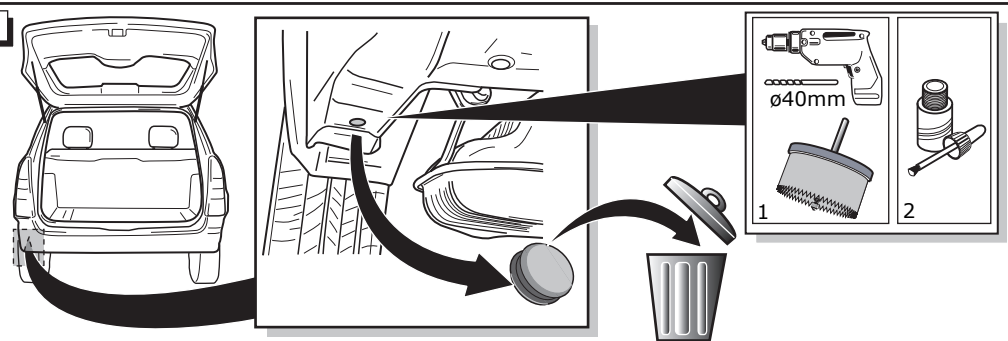

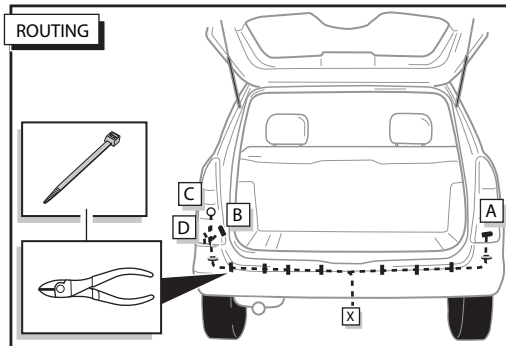
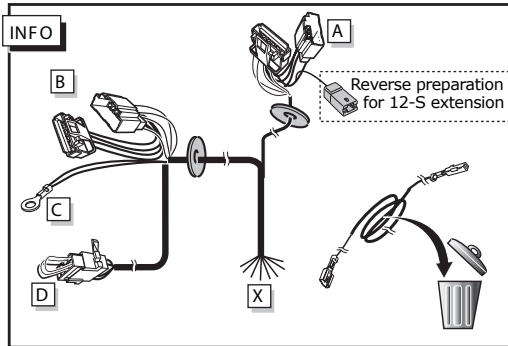
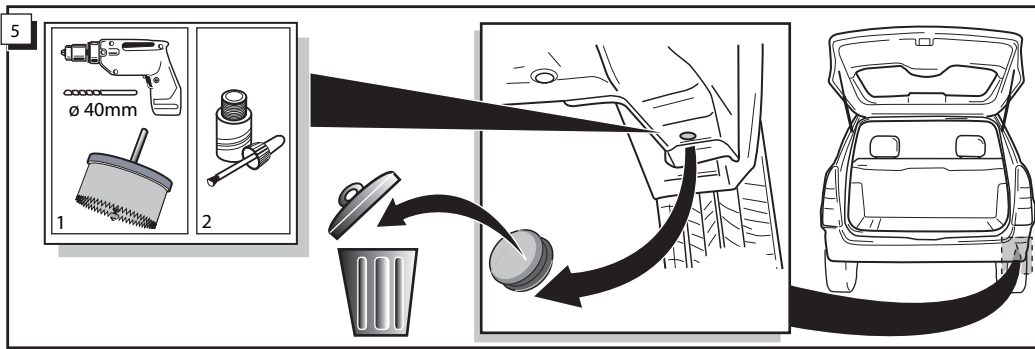

INFO Anschluß Steckdose / Connection de la prise / Socket connection / Contactdoos aansluiting

DIN/ISO 1724		(D)	(F)	(GB)	(NL)
	1/L	gelb	jaune	yellow	geel
	2	blau	bleu	blue	blauw
	3/31	weiß	blanc	white	wit
	4/R	grün	vert	green	groen
	5/58-R	braun	marron	brown	bruin
	6/54	rot	rouge	red	rood
	7/58-L	schwarz	noir	black	zwart
	8/58-b	grau	gris	grey	grijs

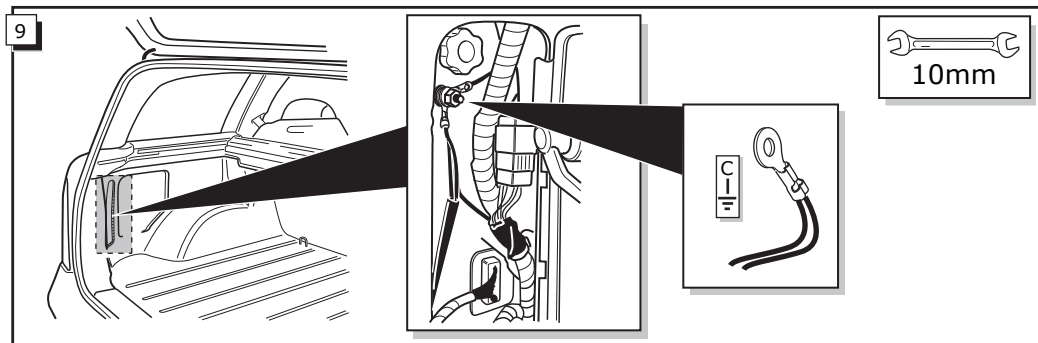
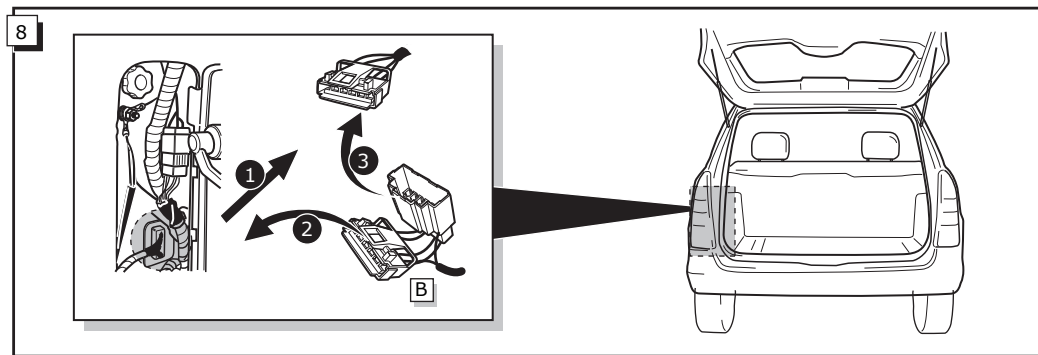
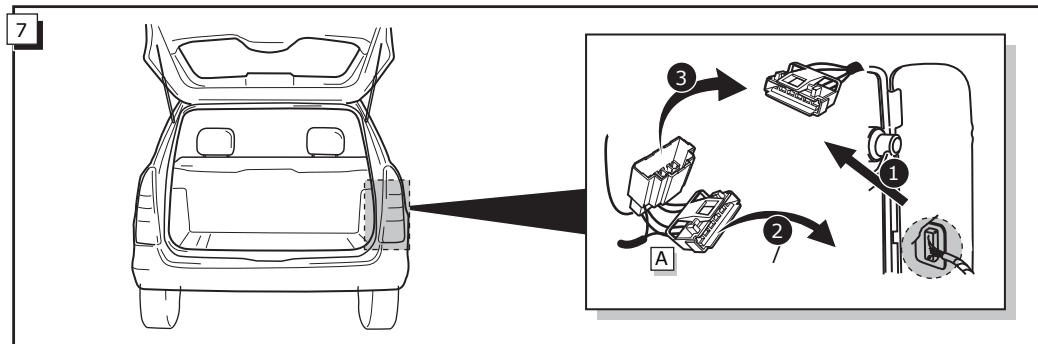
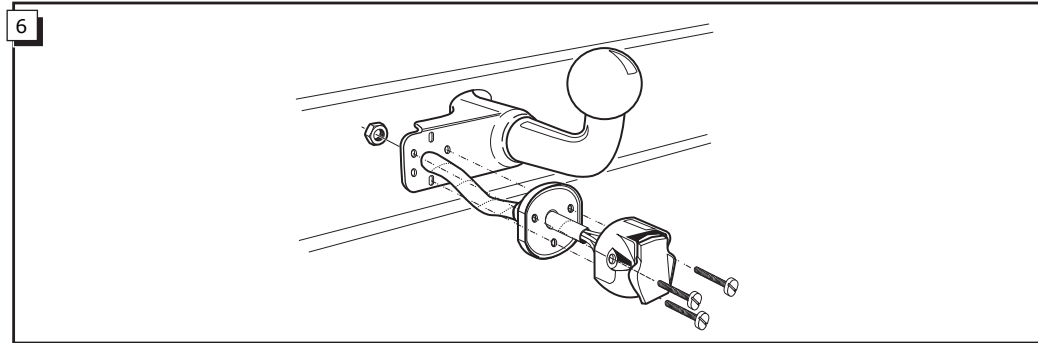
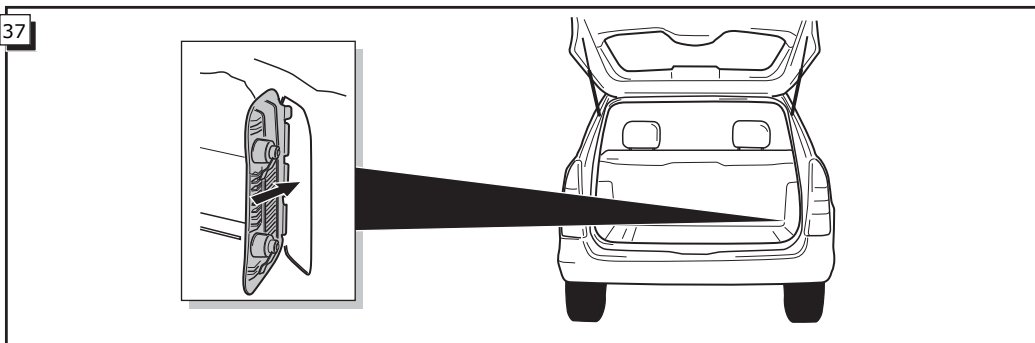
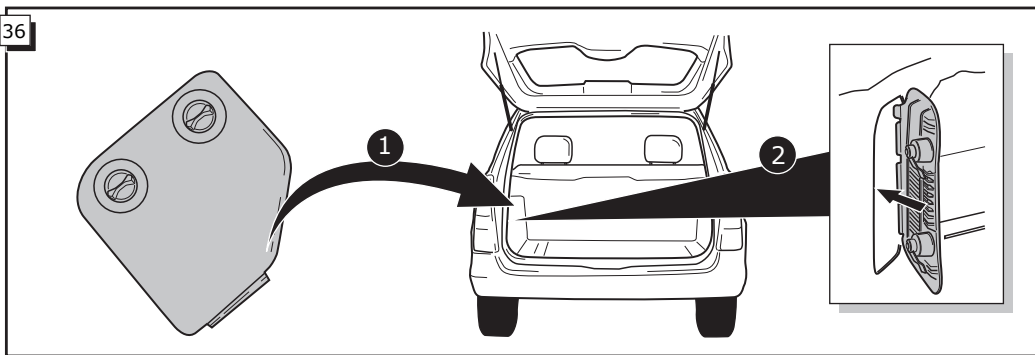
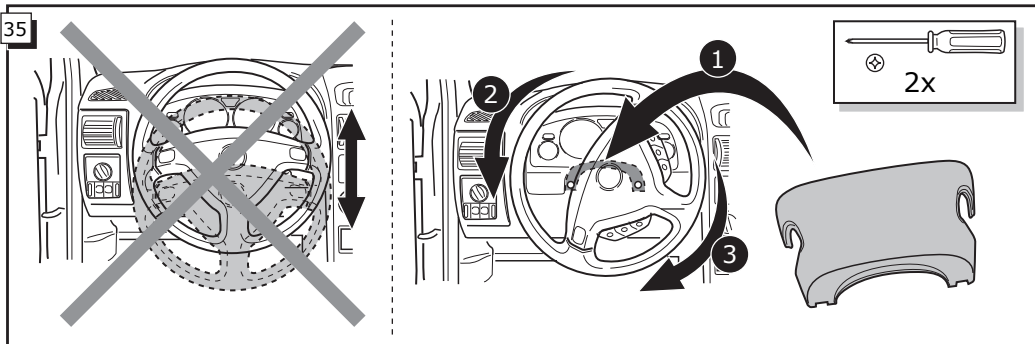
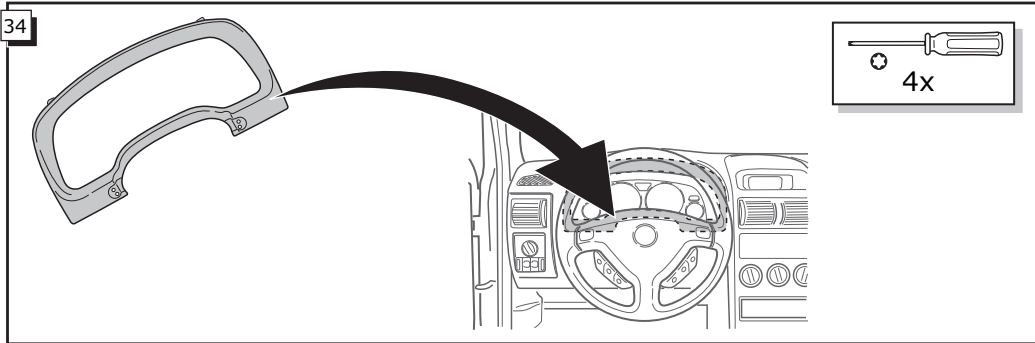

INFO

- * Fahrzeuge mit check control: bei Abbildung 10 weitergehen. Fahrzeuge ohne check control: bei Abbildung 17 weitergehen.
- * Véhicules avec check control: continuez chez figure 10. Véhicules sans check control: continuez chez figure 17.
- * Vehicles with check control: continue at picture 10. Vehicles without check control: continue at picture 17.
- * Voertuigen met check control: ga verder bij afbeelding 10. Voertuigen zonder check control: ga verder bij afbeelding 17.

10

- * Mit Check Control: Informieren Sie sich bei ihrem Lieferanten nach einem Erweiterungssatz.
- * Avec check control: Informez chez votre fournisseur pour un faisceau d'extension.
- * With check control: contact your supplier for an extension kit.
- * Met check control: informeer bij uw leverancier naar een uitbreidingsset.

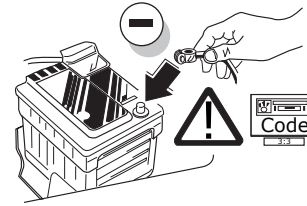
30**31**

- **FUNKTIONEN KONTROLIEREN !**
- **CONTRÔLER LES FONCTIONS !**
- **CHECK FUNCTIONS !**
- **CONTROLEER FUNCTIES !**

INFO

- Erweiterungssatz für Fahrzeuge mit Check Control.
- Faisceau d'extension pour véhicules avec check control.
- Extension kit for vehicles with check control.
- Uitbreidingsset voor voertuigen met check control.

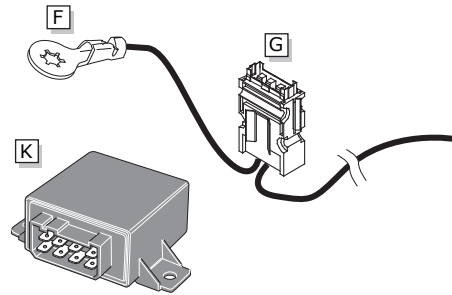
**INFO**

- Die Kontrollleuchte blinkt, wenn beim angeschlossenen Anhänger die Blinker (3x21W) oder Warnblinkanlage (6x21W) eingeschaltet sind.
- Le deuxième témoin de contrôle clignote lorsque les feux de détresses (6x21W) et les clignotants (3x21W) du véhicule sont allumés alors que la caravane/remorque est accouplée au véhicule.
- By switching on flashers with the trailer connected (3x21W) or the warning lights (6x21W), the 2nd direction indicator light will flash.
- Het controle-lampje knippert wanneer bij aangesloten aanhanger de knipperlichten (3x21W) of waarschuwingslichten (6x21W) ingeschakeld zijn.

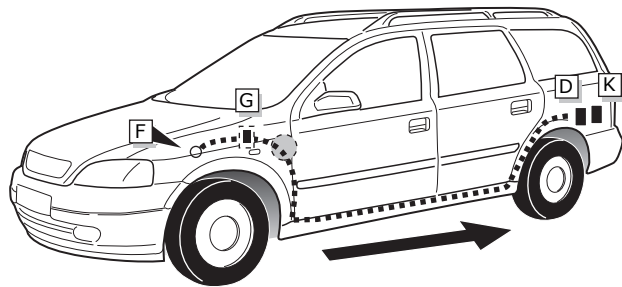
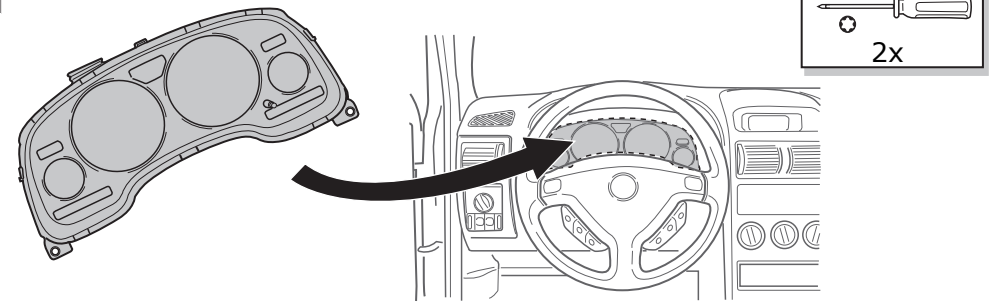
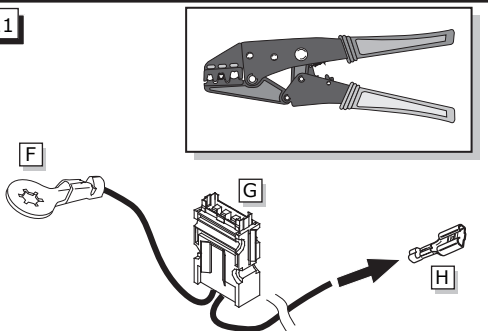
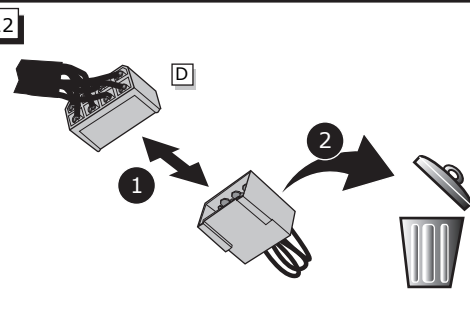
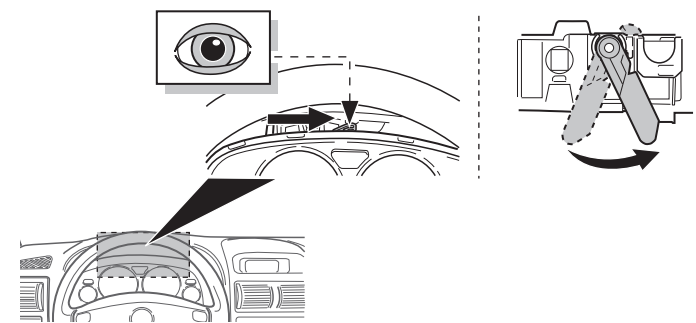
ROUTING**32****11****12****33**

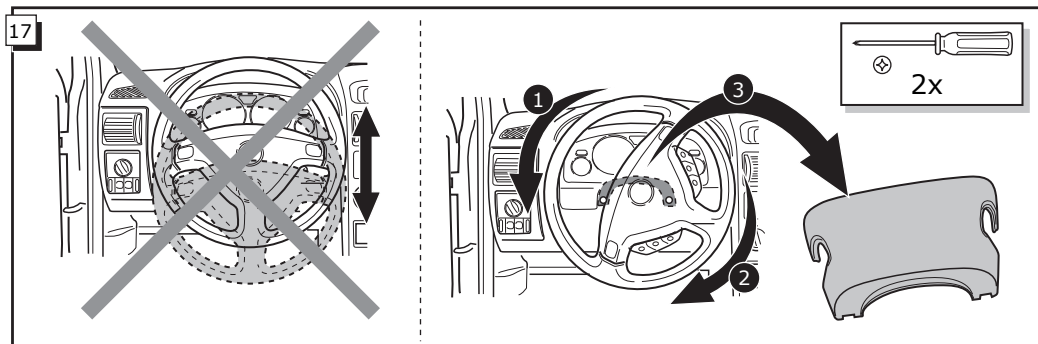
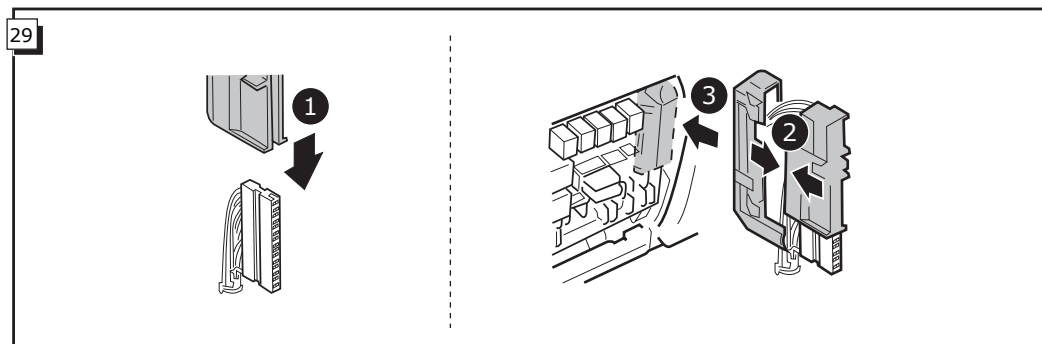
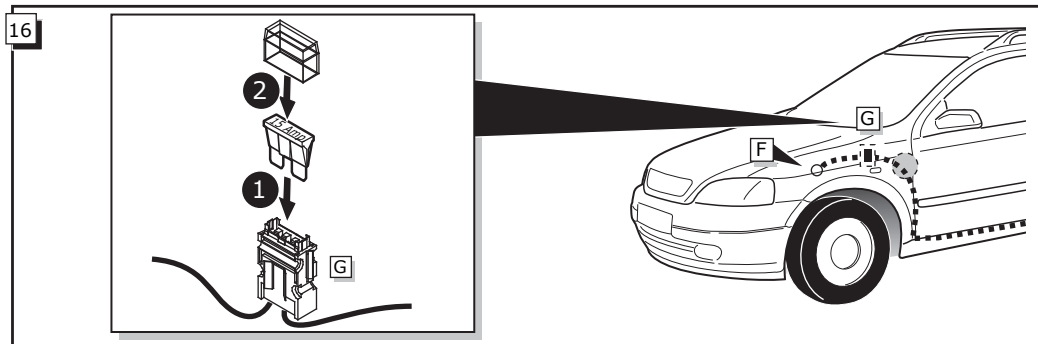
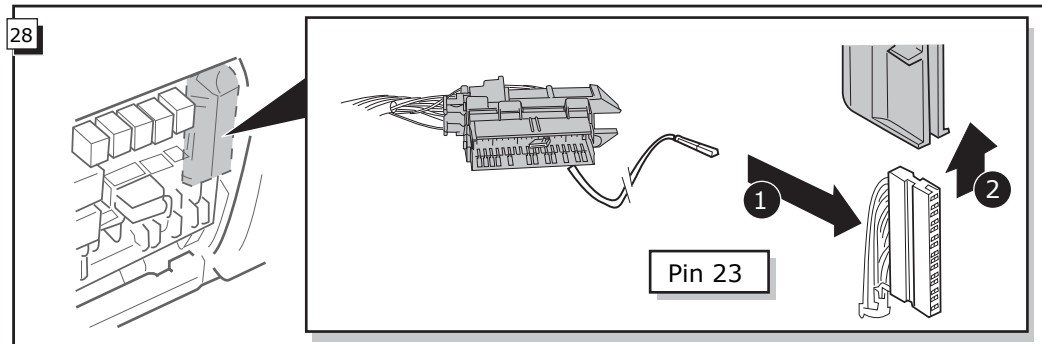
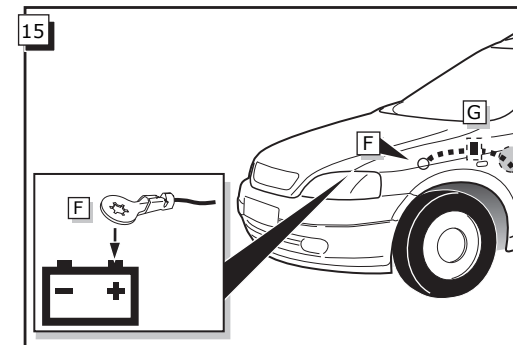
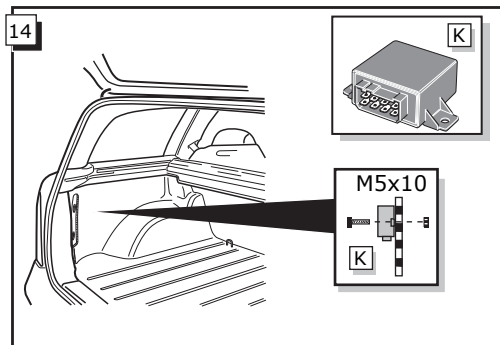
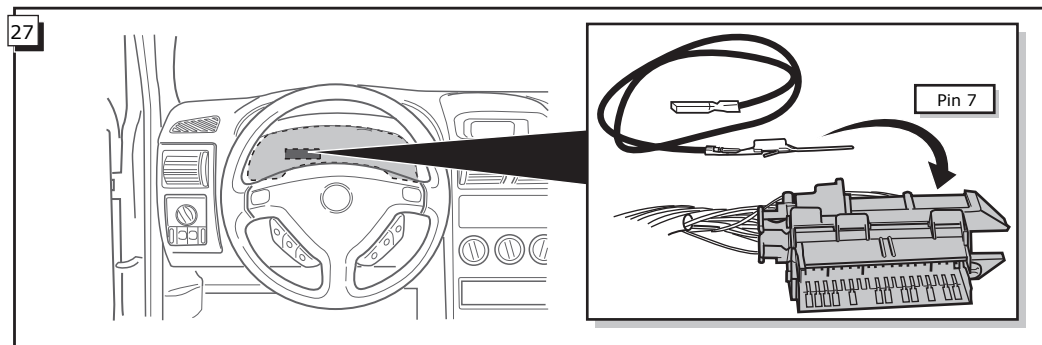
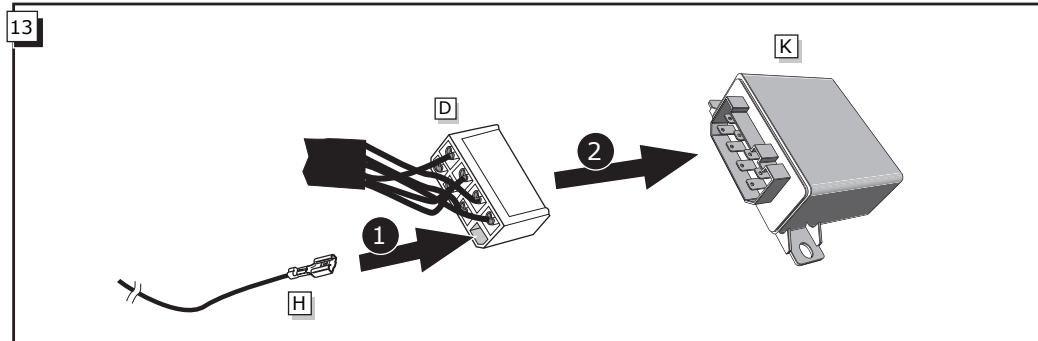
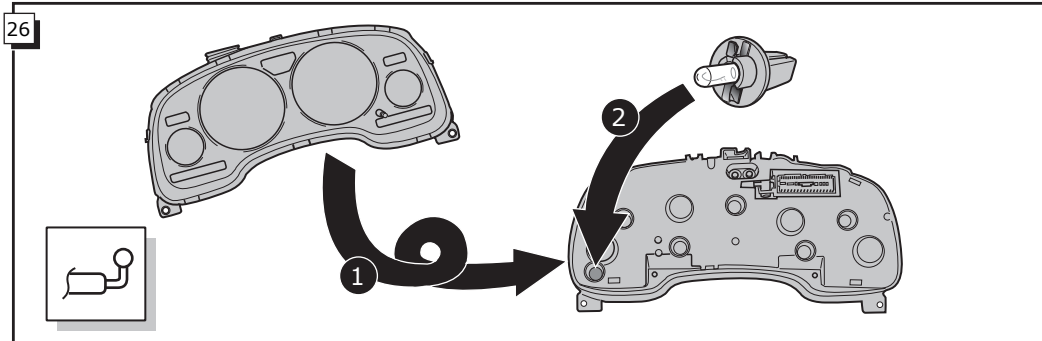

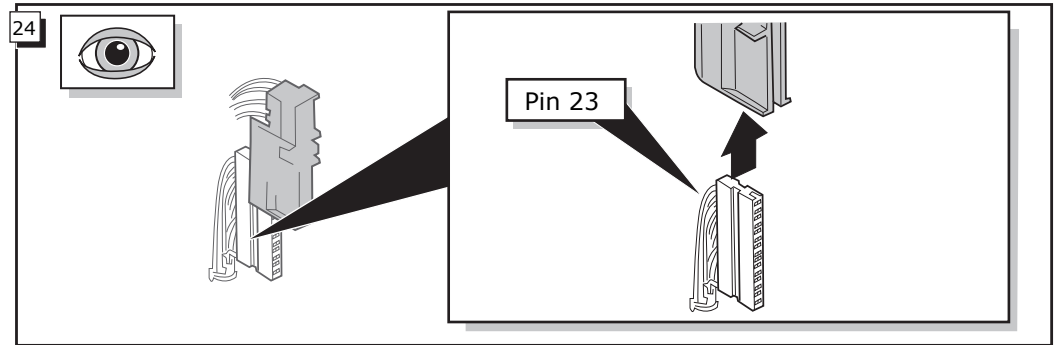
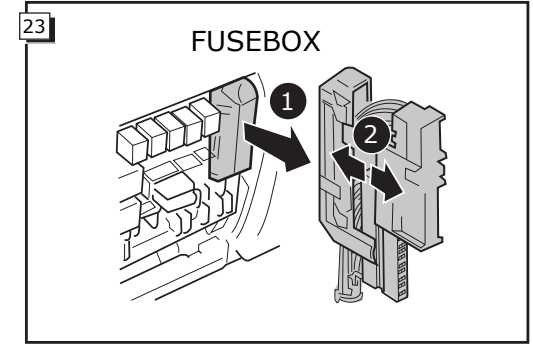
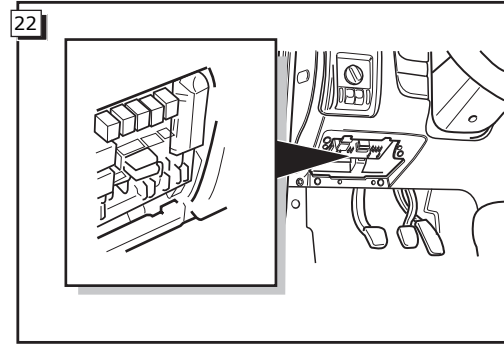
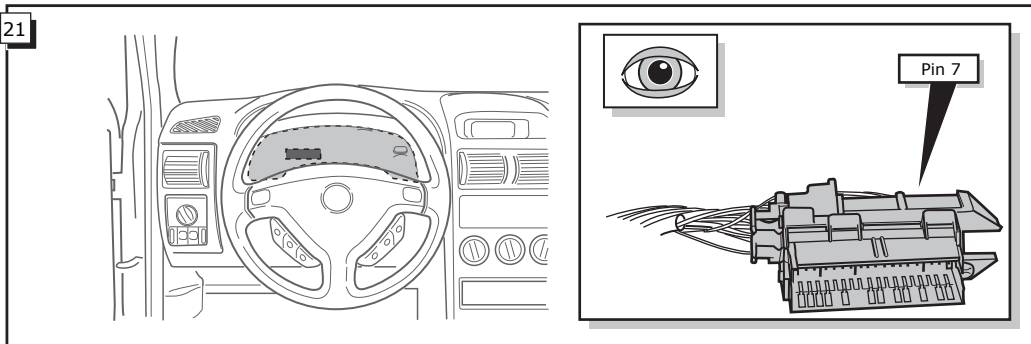
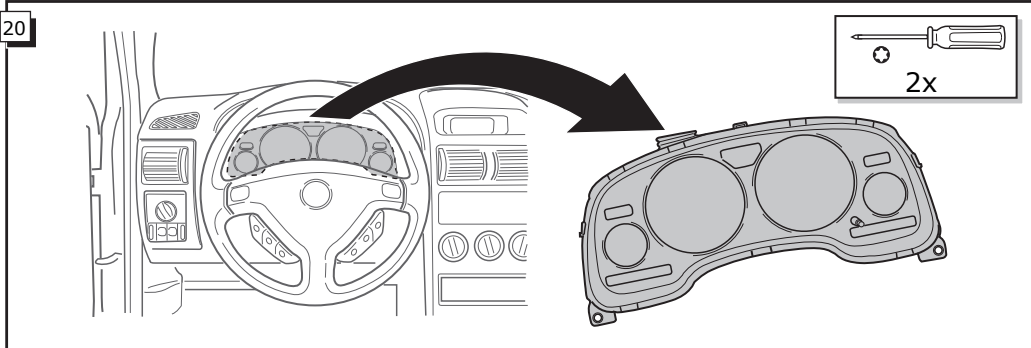
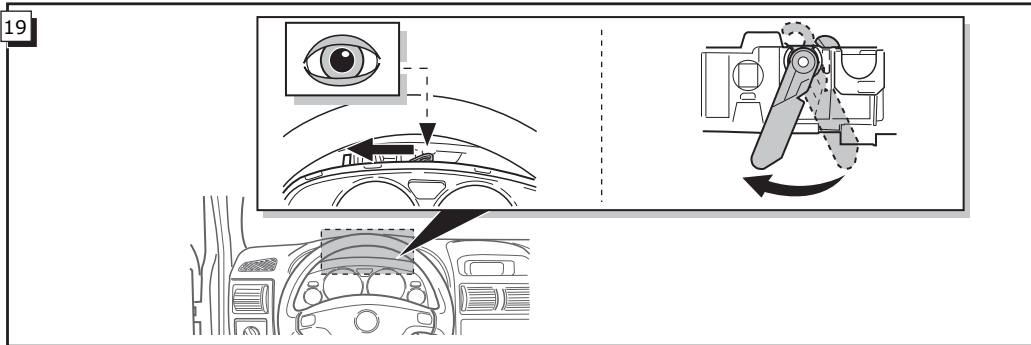
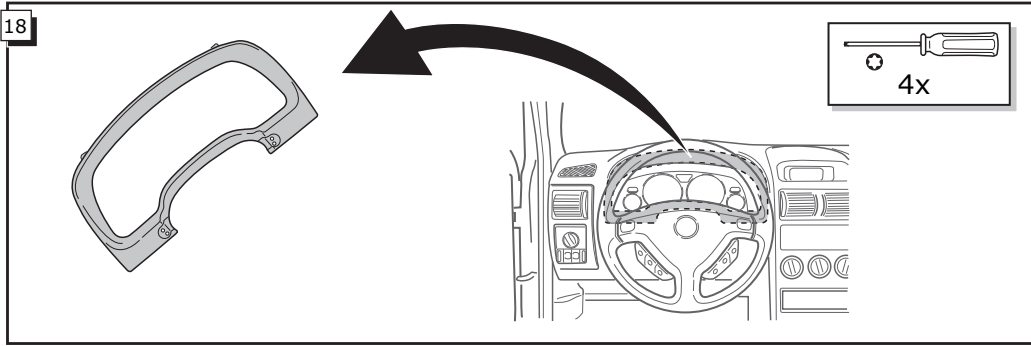

25

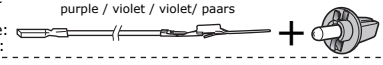
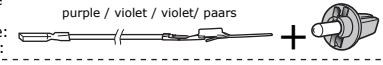
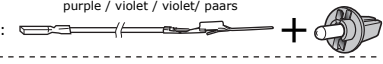
TROUBLESHOOTING	Pos. 7	Pos. 23	Action
<ul style="list-style-type: none"> <input checked="" type="checkbox"/> Besetzt / Occupé / Occupied / Bezet <input type="checkbox"/> Frei / Libre / Clear / Vrij 	●	●	Montiere Montez: Montiere: Monteer: <hr/> Sehe: Voir: See: Zie: <div style="text-align: center;">  26 </div>
Zuerst freimachen Libérer Disconnect first Eerst vrij maken	●	□	Montiere Montez: Montiere: Monteer: <hr/> Sehe: Voir: See: Zie: <div style="text-align: center;">  26 27 28 </div>
	□	●	Montiere Montez: Montiere: Monteer: <hr/> Sehe: Voir: See: Zie: <div style="text-align: center;">  26 27 28 </div>
	□	□	Montiere Montez: Montiere: Monteer: <hr/> Sehe: Voir: See: Zie: <div style="text-align: center;">  26 27 28 </div>