

bosal









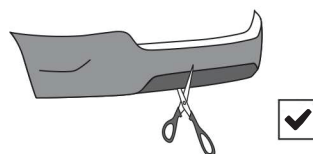



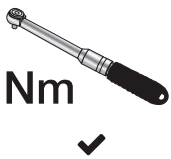

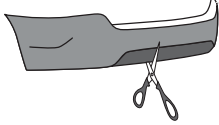

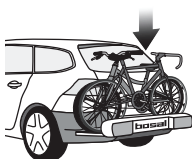



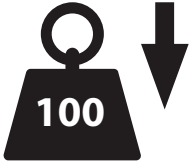
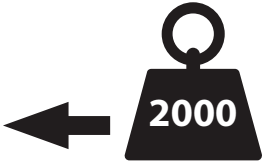

PEUGEOT 3008 II
CITROEN C5 Aircross
OPEL GRANDLAND X

Part Number: 083101

Type Number: 083101





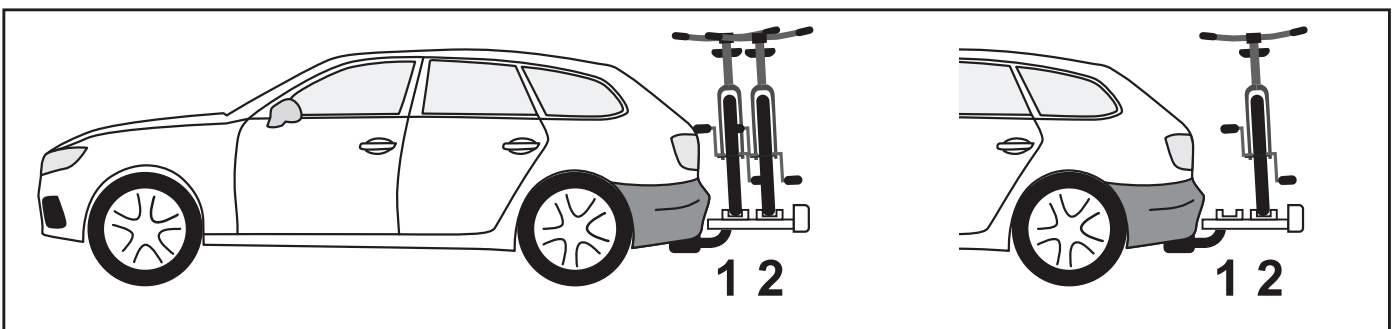
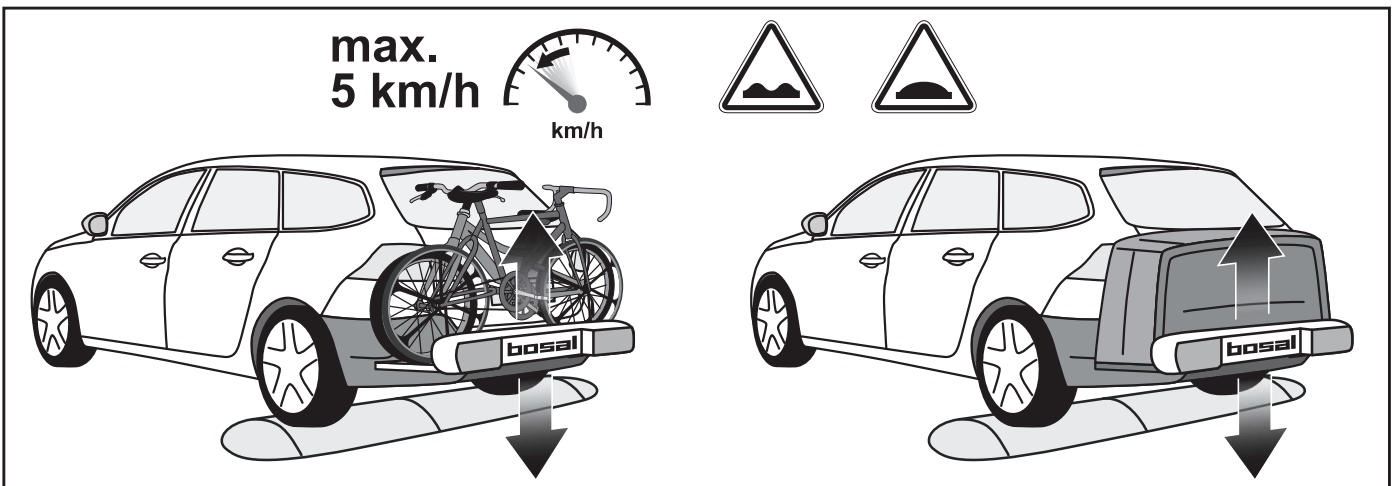
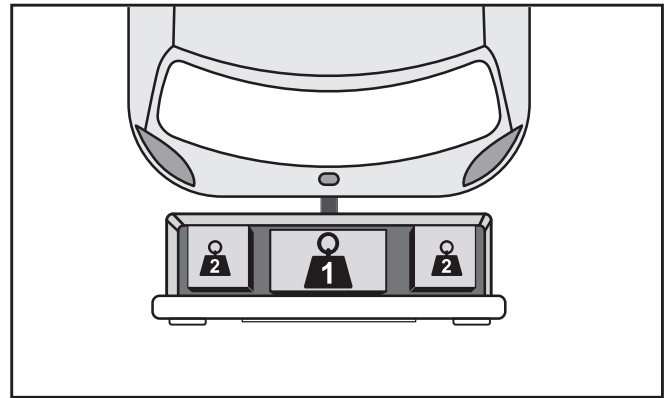
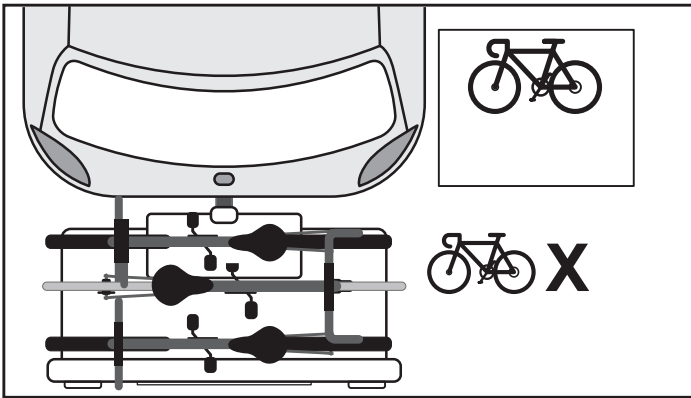
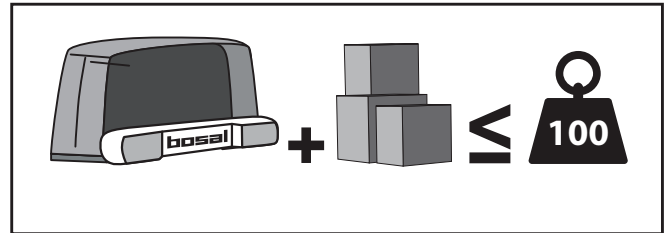
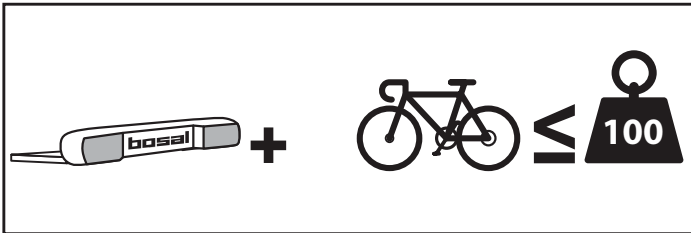
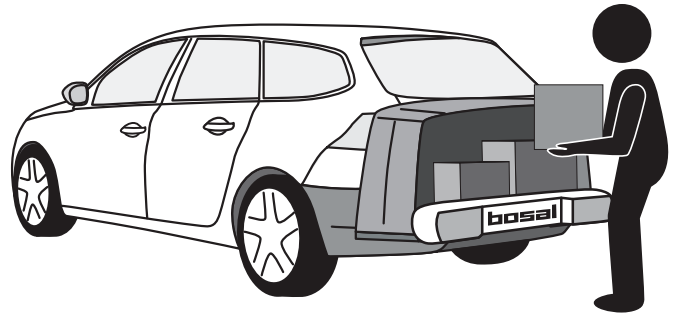
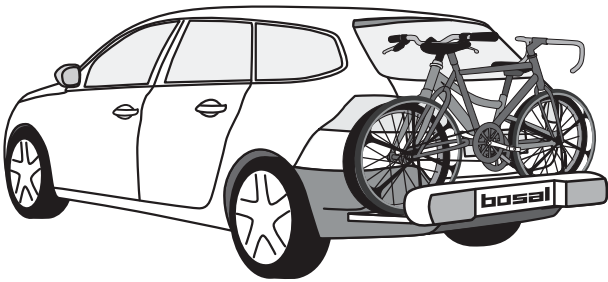

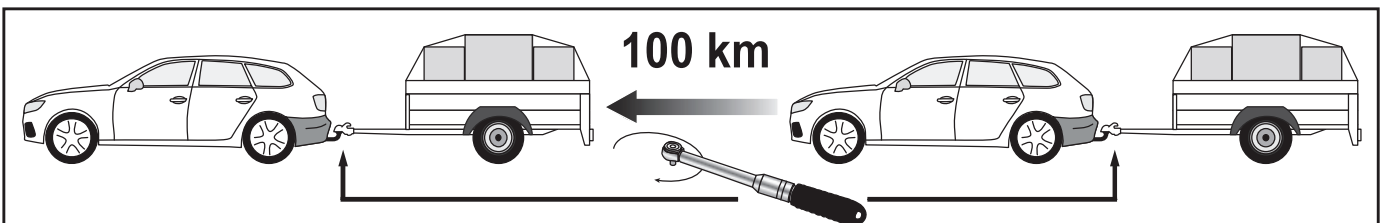
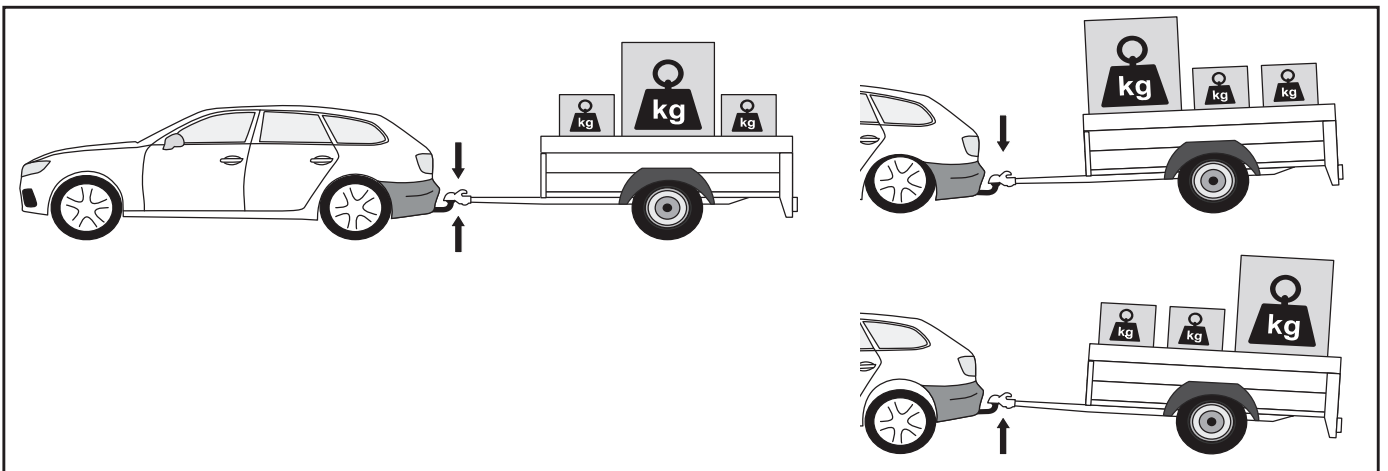
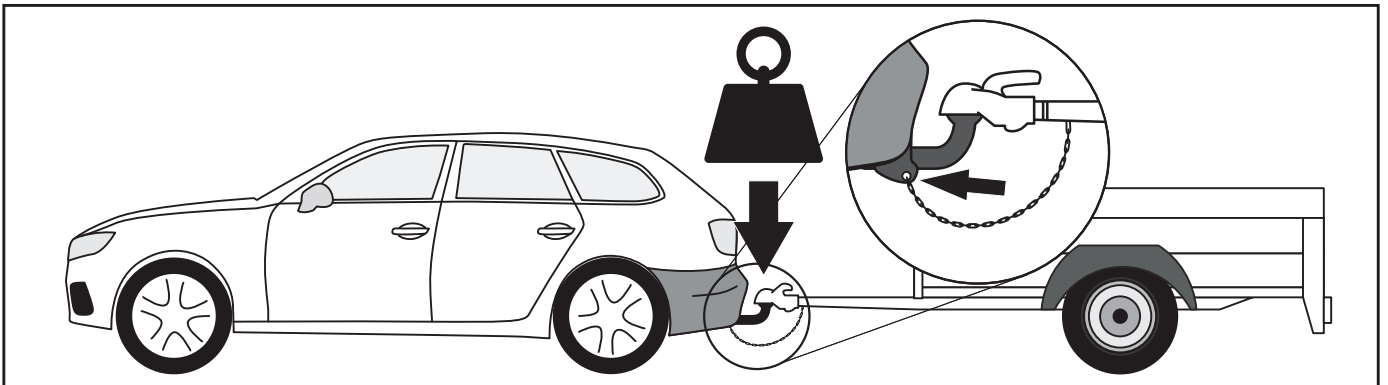
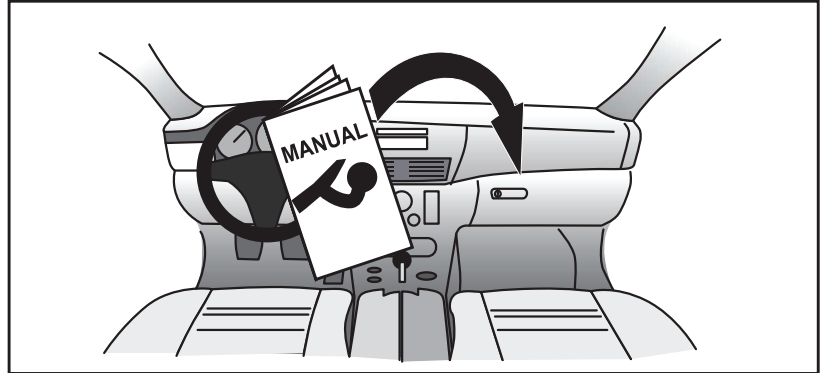
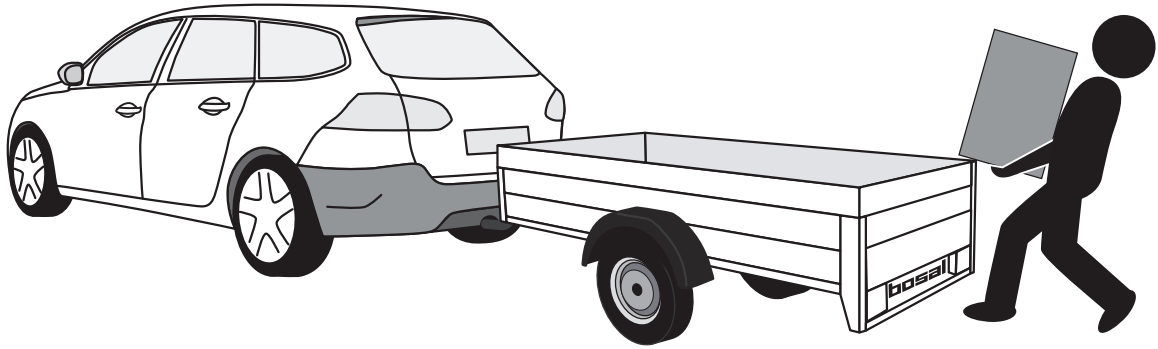

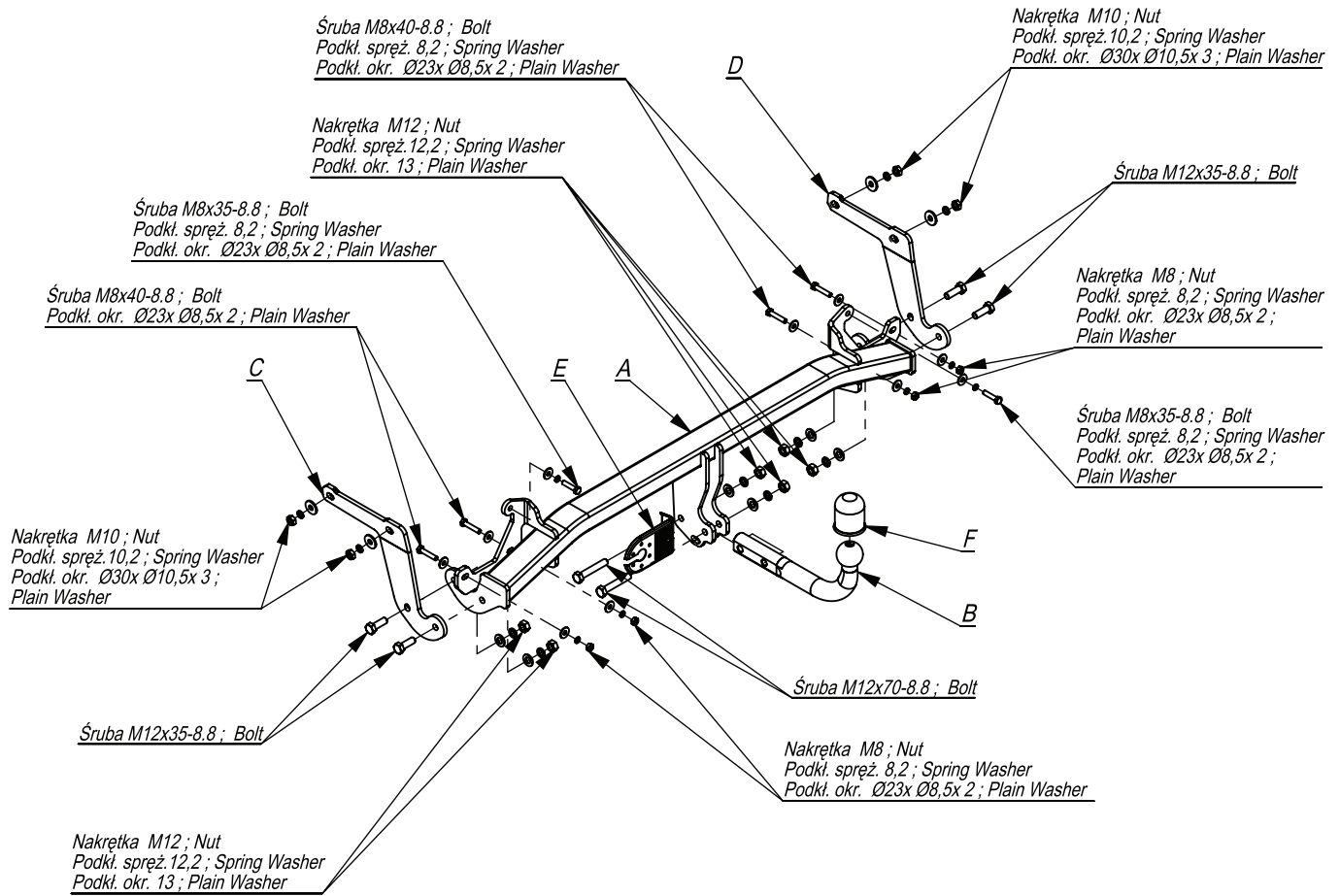

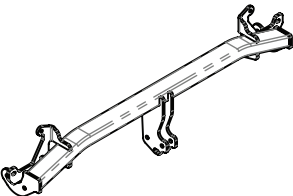
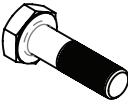
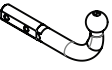

  	  	  
 	 	
		
	<p>E20*55R01/07*005972*00</p>	
 	<p>M6 = 10 M12 = 85 M8 = 25 M14 = 135 M10 = 55 M16 = 200</p>	
 	<p>MAX ↓ kg MAX ↓ kg  <hr/> MAX ↓ kg MAX ↓ kg  </p> <p>X 0,0098' ≤ 10,10</p>	
	<p>1H30</p>	







	A	x1		M12x70	2
				M12x35	4
				M8x35	2
				M8x40	4
	B	x1		M12	6
				M10	4
				M8	4
	C	x1		Ø30xØ10,5x3	4
				Ø23xØ8,5x2	10
	D	x1		13	6
	E	x1		12,2	6
	F	x1		10,2	4
				8,2	6

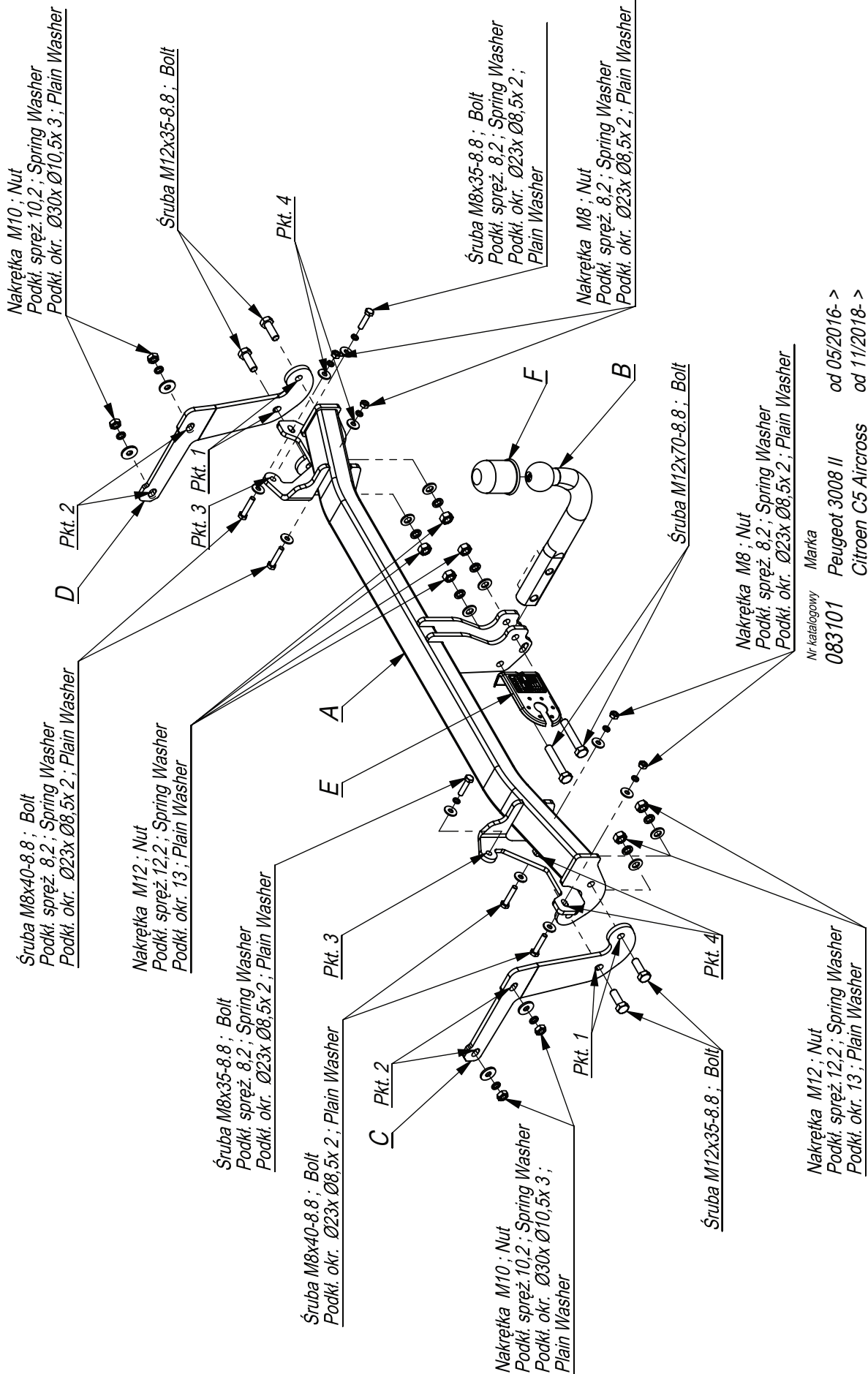

Nr katalogowy
083101
 Marka
 Peugeot 3008 II od 05/2016- >
 Citroen C5 Aircross od 1/2018- >
 Opel Grandland X od 06/2017- >

- Odkręcić zderzak i lampy.
- Odkręcić 3 śruby mocujące tylną belkę (pkt 3 i 4).
- Udrożnić otwory w podłużnicach.
- Przykręcić do tylnego pasa belkę haka A śrubami M8x40 (pkt 3 i 4).
- Elementy C i D przykręcić do podłużnic nakrętkami M10 (pkt 2) oraz do belki haka A śrubami M12x35 8.8 (pkt 1).
- Dokręcić wszystkie śruby z momentem wg tabeli.
- Przykręcić zderzak i lampy.
- Przykręcić kulę i blachę gniazda elektrycznego śrubami M12x70.
- Podłączyć instalację elektryczną.

- Unscrew the bumper and lamps.
- Unscrew three rear bar fitting bolts (point 3 and 4).
- Clear out the technological holes in the frame side members.
- Screw the main bar A to the rear belt with bolts M8x40 8.8 (point 3 and 4).
- Screw the elements C and D to the frame side members with nuts M10 (point 2) and to the main bar A with bolts M12x35 8.8 (point 1).
- Tighten all the bolts according to the torque setting- see the table.
- Screw the bumper and lamps.
- Fix the ball and electric plate with bolts M12x70.
- Connect the electric wires

- Démonter la pare choc.
- Démonter trois vis de fixation de l'absorbeur de choc à droite et à gauche du véhicule.
- Supprimer le mastic de protection aux points de fixation extérieur existant sur les longerons.
- Fixer la traverse d'attelage A aux points de fixation de l'absorbeur de choc à l'aide des 4 vis M8x40 et des deux vis M8x35.
- Fixer le renfort C sur le longeron gauche et le D au longeron droit, (voir différence entre C et D page 10) avec les écrous M10, et à la traverse d'attelage avec les boulons M12x35.
- Serrer toute la visserie aux couples (voir page 2).
- Découper le pare choc selon le détail (voir page 11).
- Remonter le pare choc, monter la rotule et le support de prise.

- Die Rückleuchten und den Stoßfänger abschrauben.
- Drei Befestigungsschrauben des hinteren Trägers abschrauben (Punkt 3 und 4).
- Die Öffnungen in den Längsträger freimachen.
- Den AHK-Querträger A mit Schrauben M8x40 (3 und 4) am hinteren Träger verschrauben.
- Die Bauteile C und D mit M10-Muttern an die Längsträger (Punkt 2) und an den AHK-Querträger A Schrauben M12x35 8.8 verschrauben..
- Ziehen Sie alle Schrauben mit dem Drehmoment gemäß der Tabelle an.
- Die Stoßstange und Rückleuchten anschrauben.
- Schrauben Sie die Kugel und den Steckdosenblech mit den Schrauben M12x70 an.
- Die Elektroinstallation anschließen.

- Desenrosque el parachoques y las lámparas.
- Desenrosque los 3 tornillos de fijación de la barra trasera (punto 3 y 4).
- Limpiar los orificios en los largueros.
- Fijar la barra del gancho a la correa trasera con tornillos M8x40 (punto 3 y 4).
- Fijar los elementos C y D a los largueros con tuercas M10 (punto 2) y a la barra del gancho A con tornillos M12x35 8.8 (punto 1).
- Apretar todos los tornillos con el par según la tabla anterior.
- Fijar el parachoques y las lámparas.
- Atornille la bola y la placa de toma de corriente eléctrica. con tornillos M12x70.
- Conectar la instalación eléctrica.

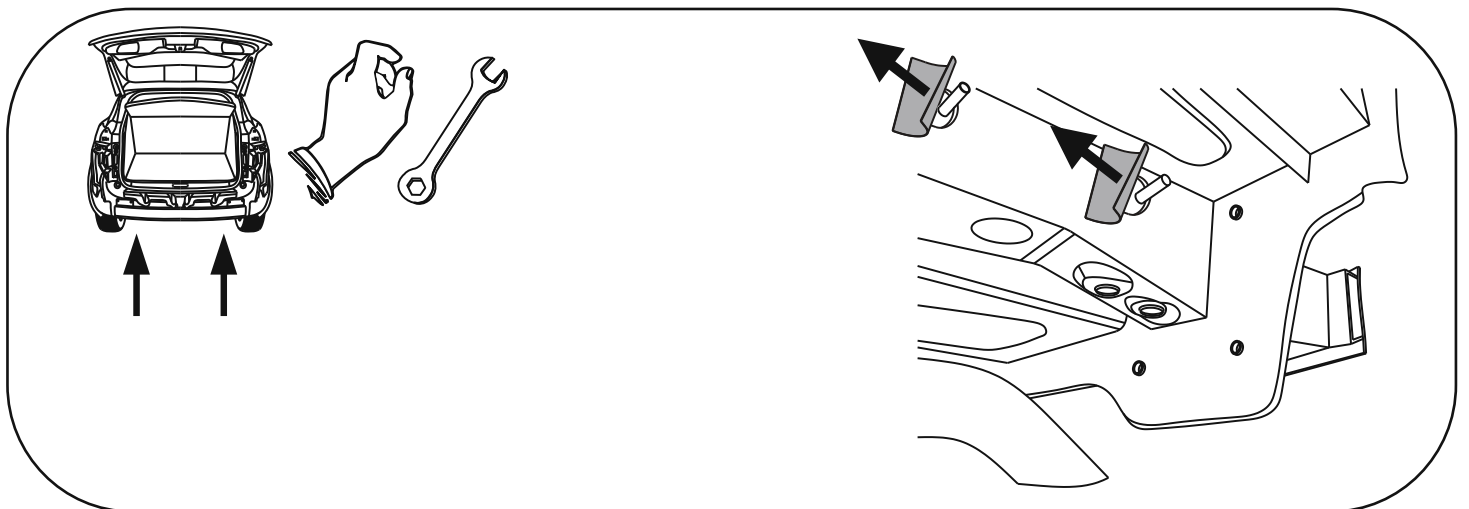
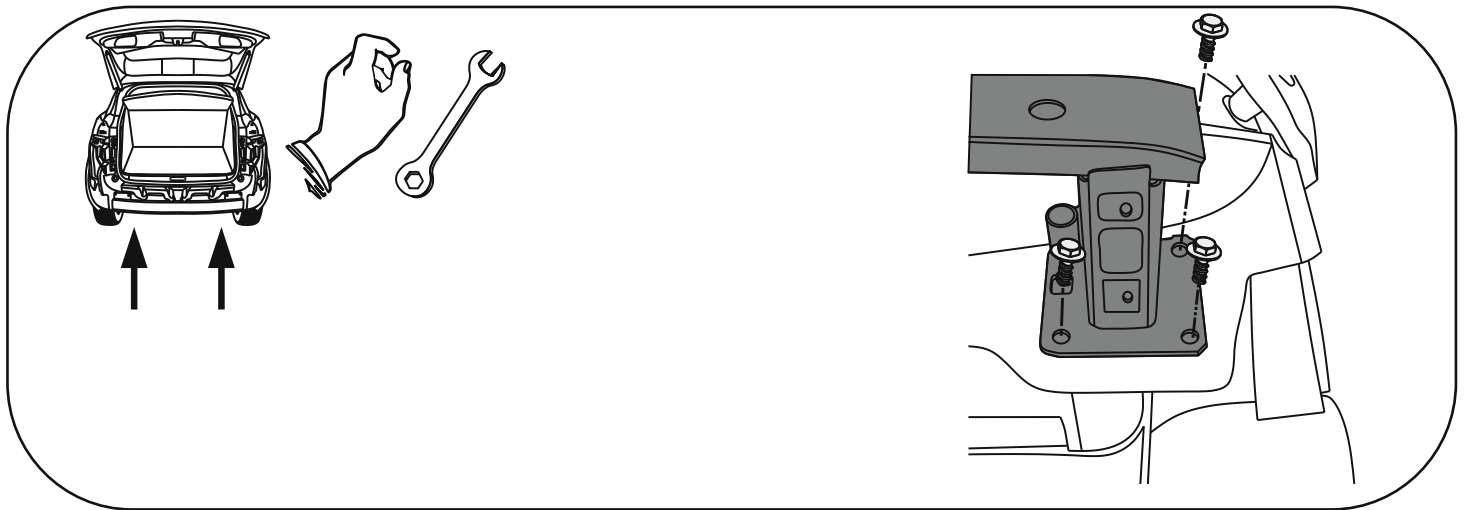
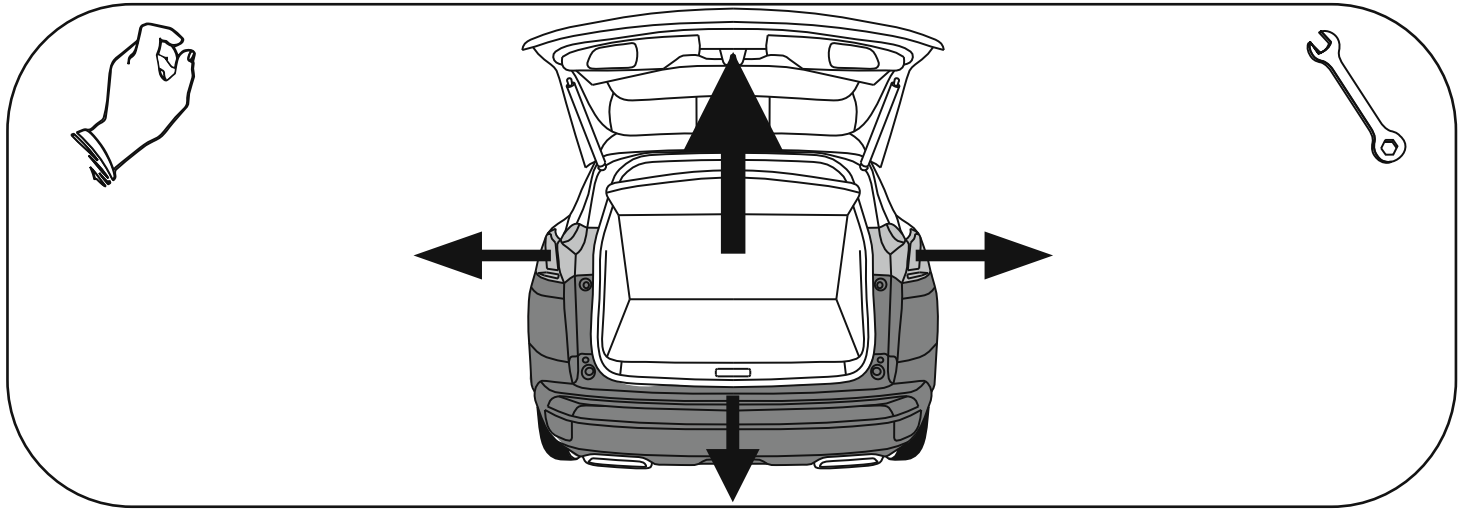

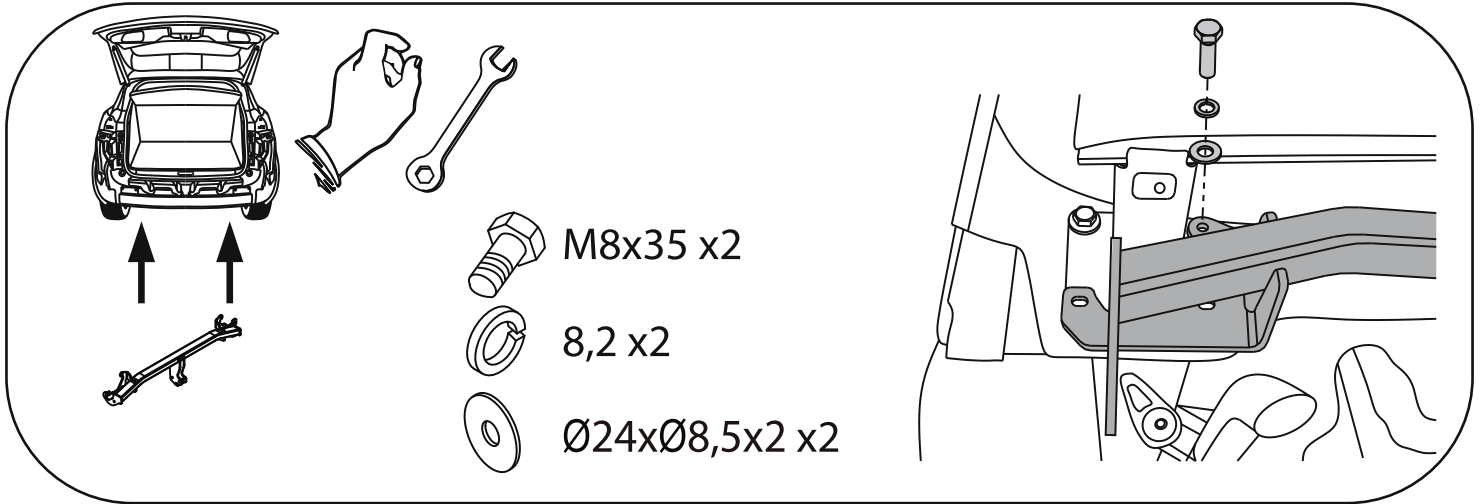

Element C

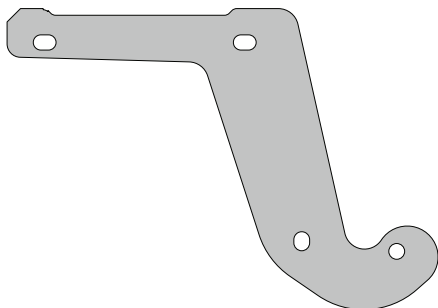

Element D

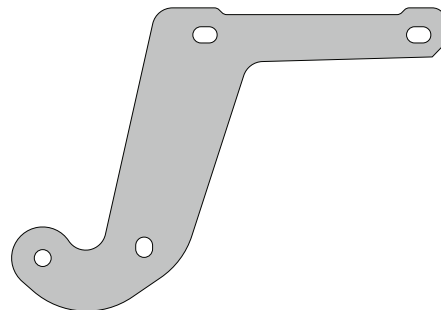

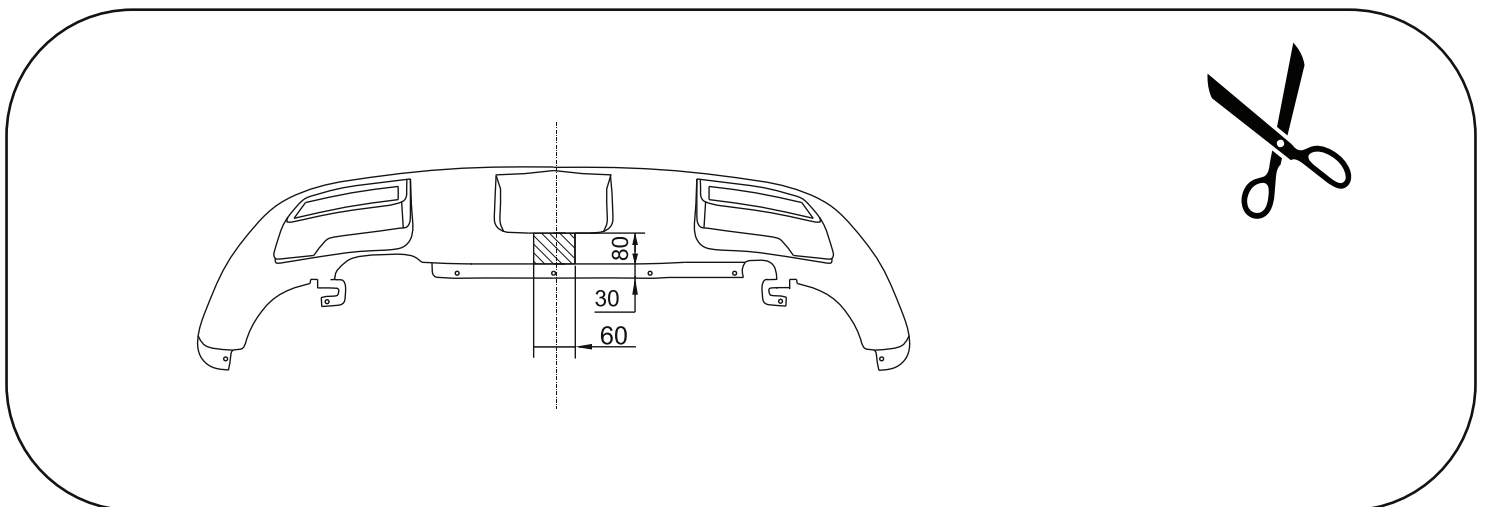
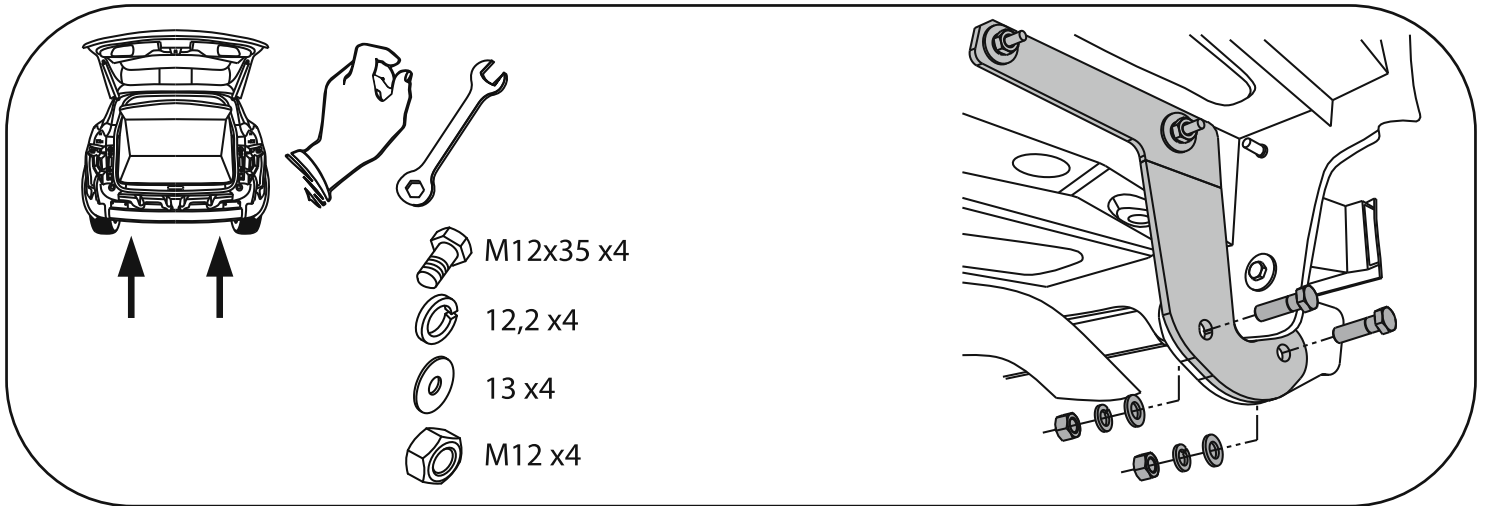
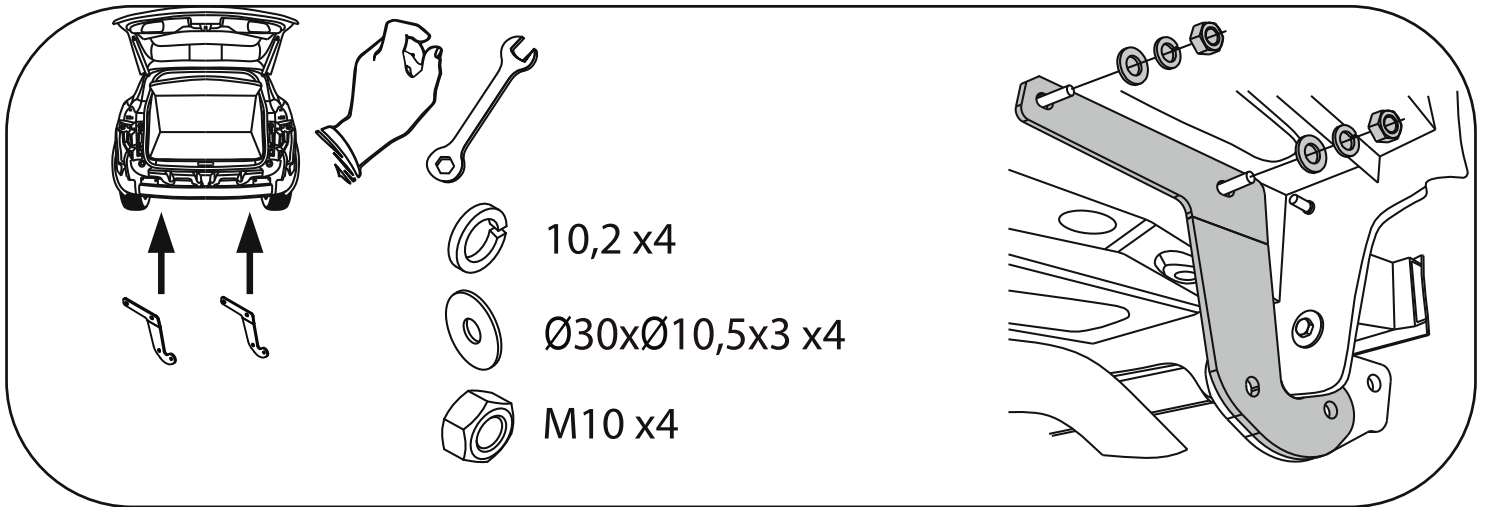

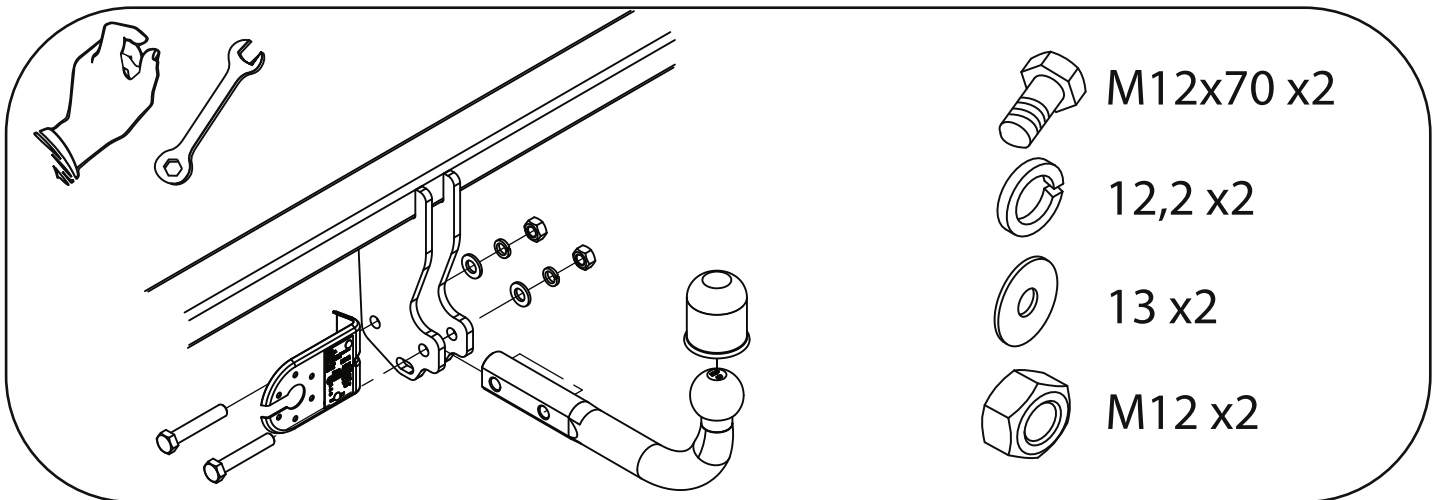
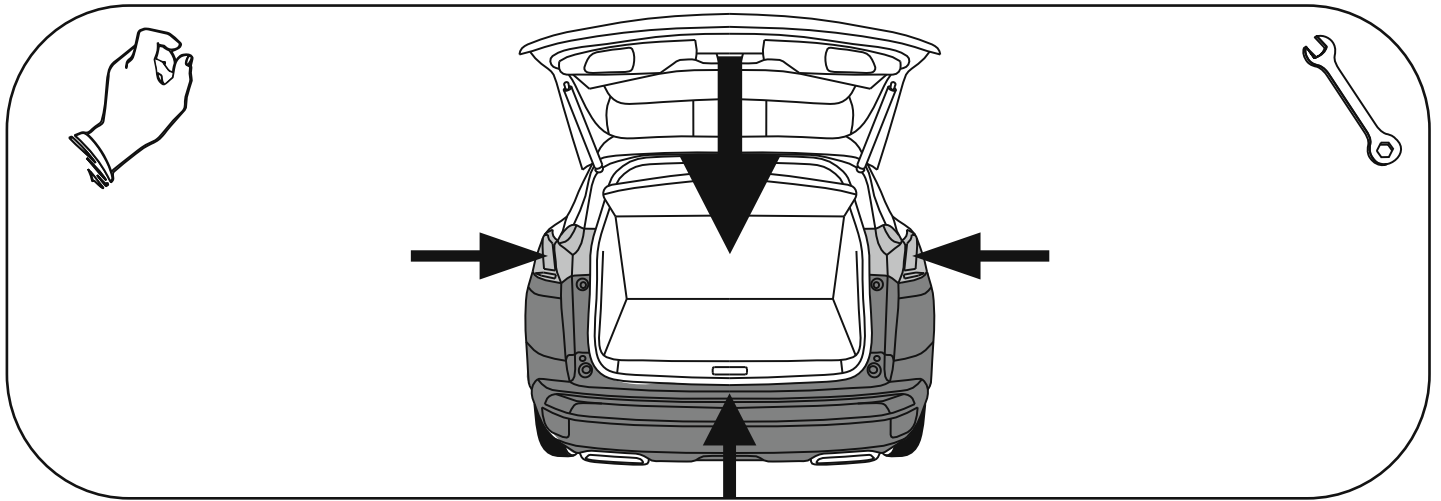

- NL** De tussenruimte conform supplement VII, afbeelding 25 van de richtlijn ECE-R 55 moet in acht worden genomen.
- D** Der Freiraum nach Anhang VII, Abbildung 25 der Richtlinie ECE-R 55 ist zu gewährleisten.
- GB** The clearance specified in appendix VII, diagram 25 of guideline ECE-R 55 must be guaranteed.
- F** La zone de dégagement doit être garantie conformément à l'annexe VII, illustration 25 de la directive ECE-R 55.
- E** Debe garantizarse el espacio libre, conforme al anexo VII, figura 25 de la directiva comunitaria ECE-R 55.
- DK** Frirummet skal overholdes iht. bilag VII, fig. 25 i direktiv ECE-R 55.
- N** Frirommet etter tillegg VII, figur 25 i direktiv ECE-R 55 skal overholdes.
- S** Spelrummet enligt bilaga VII, figur 25 i riktlinje ECE-R 55 skall garanteras.
- FIN** Vapaa tila on taattava direktiivin ECE-R 55 liitteen VII, kuvan 25 mukaisesti.
- I** Deve essere garantito lo spazio libero secondo l'allegato VII, figura 25 della direttiva ECE-R 55.
- CZ** Volný prostor ve smyslu Přílohy VII, obr. 25 Směrnice č. ECE-R 55 musí být zaručen.
- PL** Należy zagwarantować wolną wysokość określoną na rysunku nr 25 dyrektywy ECE-R 55 zawartej w załączniku nr VII.
- H** Az ECE-R 55 irányelv VII. mellékletében, a 25. ábrán a vonógömb elhelyezése számára előírt szabad tér-adatokat biztosítani kell.
- RU** Необходимо обеспечить данные свободного пространства, предписанные для размещения тягового шарика в приложении VII. директивы ECE-R 55.

шарика в приложении VII. директивы ECE-R 55.

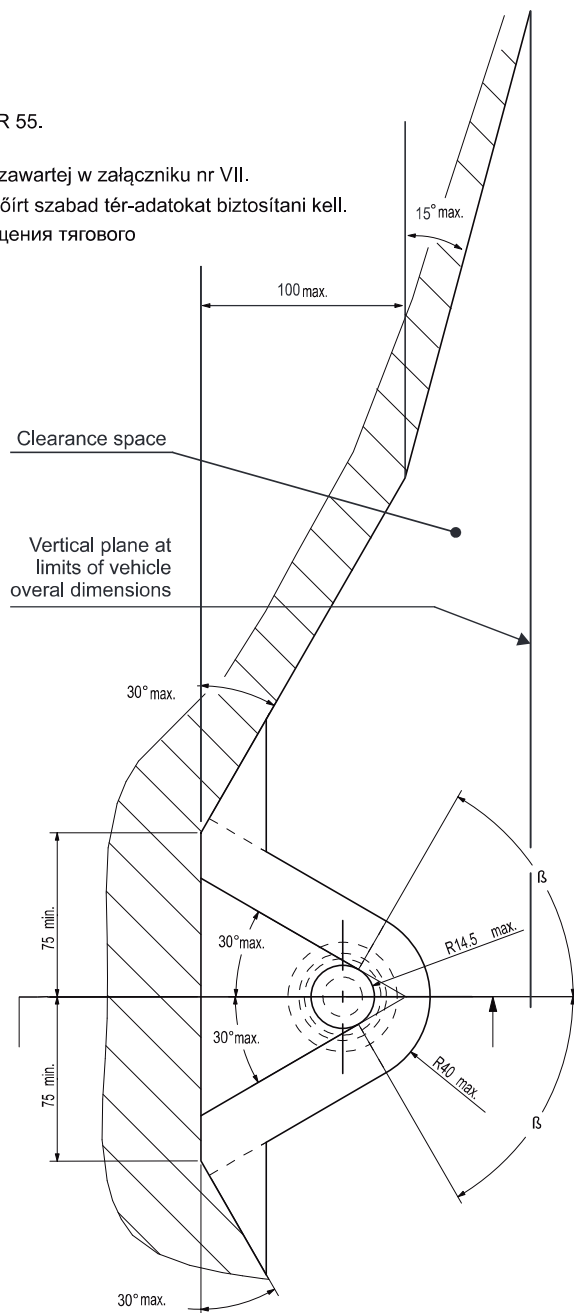
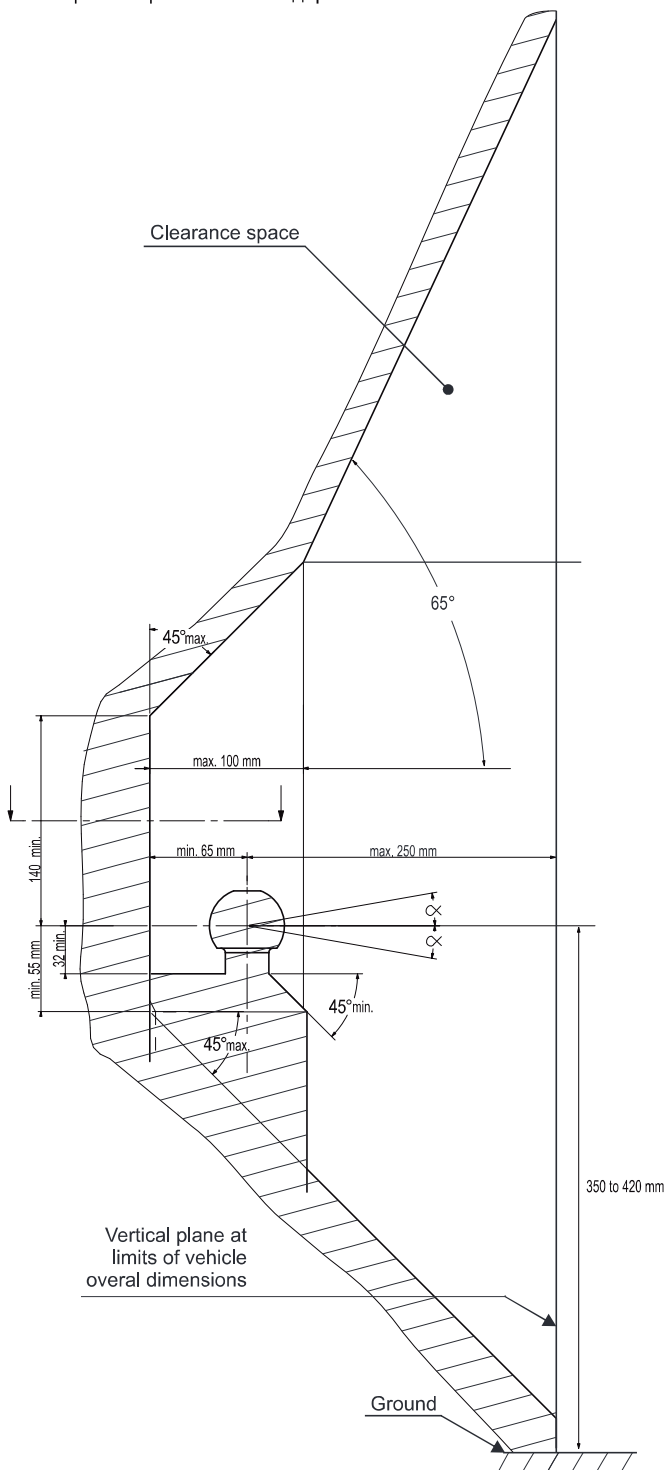

- NL** bij toelaatbaar totaal gewicht van het voertuig
- D** bei zulässigem Gesamtgewicht des Fahrzeuges
- GB** at laden weight of the vehicle
- F** pour poids total en charge autorisé du véhicule
- E** con peso total autorizado del vehículo
- DK** ved tilladt samlet vægt for køretøjet
- N** ved kjøretøyets tillatte totalvekt
- S** vid fordonets tillåtna totalvikt
- FIN** ajoneuvon suurimmalla sallitulla kokonaispainolla
- I** per un peso complessivo ammesso del veicolo
- CZ** při celkové přípustné hmotnosti vozidla
- PL** w przypadku największej dozwolonej masy całkowitej
- H** rakománnyal terhelt járműsúly esetén.
- RU** В случае нагруженного автомобиля.

LA GARANTIE

En cas d'utilisation de l'attelage, les instructions du constructeur du véhicule concernant le poids tractable maximum autorisé ainsi que la charge verticale maximum sur la boule doivent être respectées. Ces instructions se trouvent dans les documents de bord du véhicule et dans le certificat WVTa. Merci de vous rapprocher du concessionnaire de la marque de votre véhicule afin de connaître son poids maximum tractable. Il est interdit de dépasser les charges données dans les documents qui accompagnent l'attelage.

Avant de tracter, raccorder la connexion électrique, et la chaîne de sécurité qui permet l'arrêt automatique de la remorque en cas de rupture de l'attelage.

Dans un cas extrême, la surcharge de l'attelage peut entraîner sa rupture et la perte du véhicule tracté (remorque, caravane, porte vélo...). La conséquence peut être une blessure grave ou mortelle pour les occupants du véhicule tracteur et/ou les piétons et usagés de la route.

Bosal décline toute responsabilité pour les défauts éventuels du produit causés par une mauvaise utilisation (y compris la surcharge) occasionnée par l'utilisateur.

Il est interdit d'utiliser des points de fixation autres que ceux mentionnés dans la notice de pose de l'attelage.

Avant la commercialisation, tous nos attelages sont soumis à un test dynamique de longévité (2 millions de cycles).

Bosal décline toute responsabilité en cas d'adjonction de stabilisateur ou répartiteur de charge entre le véhicule tracteur et tracté.

La garantie ne s'applique qu'aux produits neufs, Bosal n'engagera pas sa responsabilité sur un produit d'occasion.

RADARS DE REcul

Il est possible que la rotule soit détectée, dans ce cas, il est nécessaire de la déposer lorsqu'elle n'est pas utilisée.

Bosal recommande fortement le montage de l'attelage démontable sans outil lorsque le véhicule est équipé de radars de recul.