



# LuK GearBOX repair solution for double clutch transmission



Disassembly and assembly  
Special tool

Ford, 6-speed transmission DPS6  
Renault, 6-speed transmission DC4

From 08/2011



The content of this brochure is not legally binding and is solely intended for information purposes. Insofar as is legally permissible, Schaeffler Automotive Aftermarket GmbH & Co. KG does not accept any liability in connection with this brochure.

All rights reserved. This brochure must not be duplicated, distributed, reproduced or made publicly accessible or otherwise published, either in whole or in part, without the prior written consent of Schaeffler Automotive Aftermarket GmbH & Co. KG.

Copyright ©  
Schaeffler Automotive Aftermarket GmbH & Co. KG  
January 2018

## Schaeffler in the Automotive Aftermarket – more innovation, more quality and more service.

### Schaeffler in the Automotive Aftermarket – always the first choice for vehicle repair.

Whenever a vehicle needs to go to the garage, our products and repair solutions are first choice to fix them. With our four strong brands LuK, INA, FAG, and Ruville, and our service brand REXPERT, we are a reliable partner around the world. Whether passenger cars, light and heavy commercial vehicles, or tractors – our optimally tuned components allow fast and professional parts replacement.

Our products are based on a comprehensive systems approach. Innovation, technical expertise, and the highest material and manufacturing quality make us not only one of the leading development partners for vehicle manufacturers, but also a pioneering provider of value-retaining spare parts and complete repair solutions for clutches and clutch release systems, engine and transmission applications, and chassis applications in original-equipment quality – right up to the appropriate special tools.

For over 50 years, we have offered everything needed for transmission repair under the LuK brand. Besides the LuK RepSet family and products for the entire hydraulic release system for professional clutch repair, the portfolio also includes the dual mass flywheel and components for expert repair of transmissions and differentials. It also includes professional solutions for transmission repair of commercial vehicles and tractors.

### Schaeffler REXPERT – the service brand for garage professionals.

With REXPERT, we offer a comprehensive service package for the products and repair solutions of the LuK, INA, FAG, and Ruville brands. Looking for specific information about failure diagnosis? Are you in need of particular tools to help make your everyday garage routine easier? Whether online portal, service hotline, installation instructions and videos, training seminars, or events – you get all technical services from a single source.

Register now for free, in just a few clicks, at: [www.rexpert.com](http://www.rexpert.com).

SCHAEFFLER  
REXPERT



The spare parts contained in the LuK GearBOX can be assigned to the relevant installation position in the transmission with the help of the parts list and this brochure. The figures in diagram are used for this purpose, such as (1).

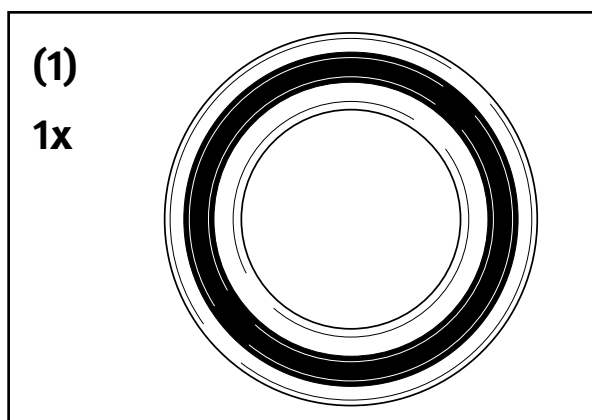

Fig. 1

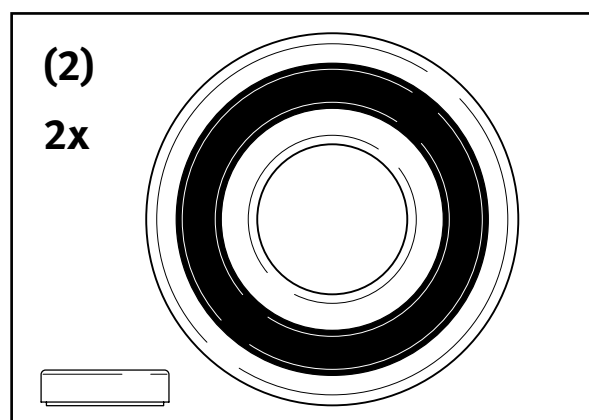

Fig. 2

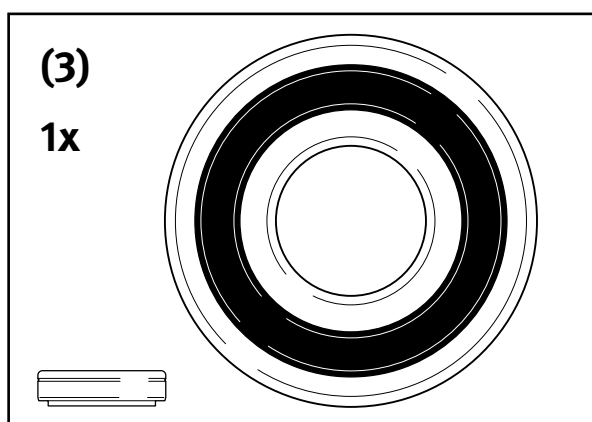

Fig. 3

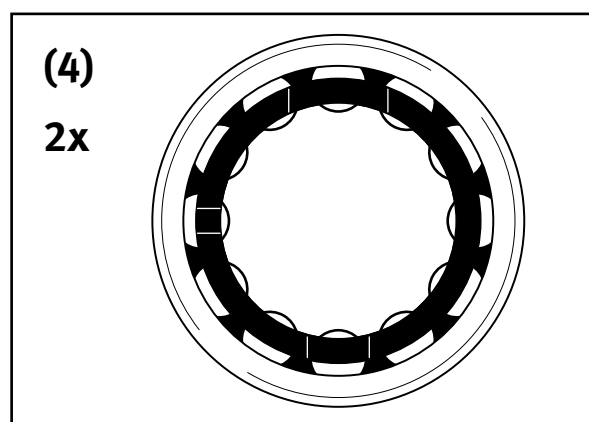

Fig. 4

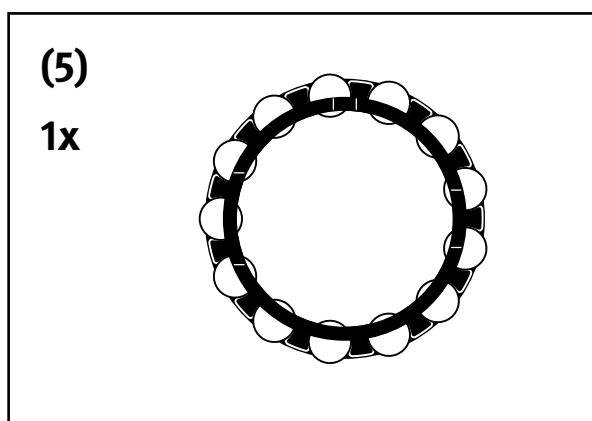

Fig. 5

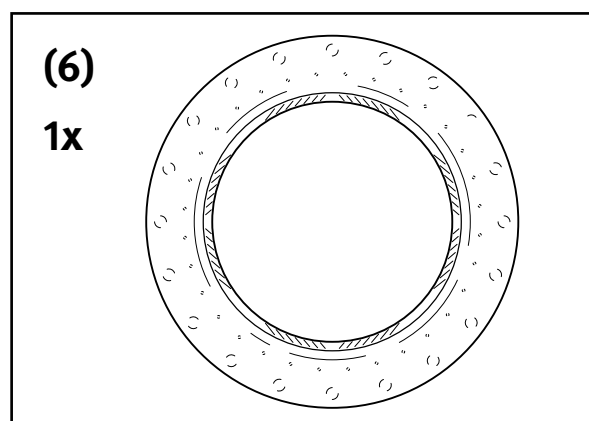

Fig. 6

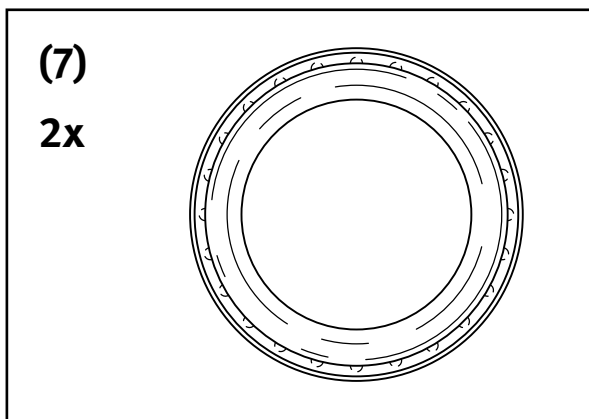

Fig. 7

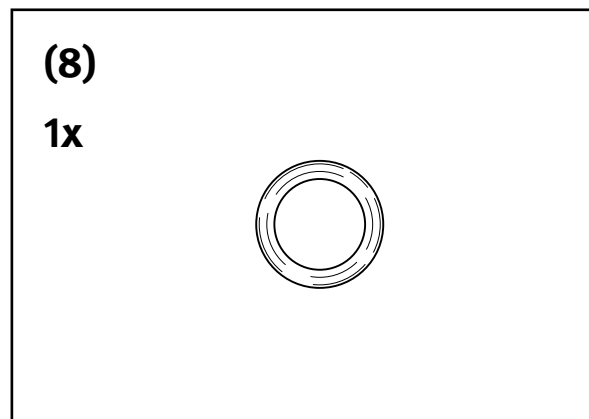

Fig. 8

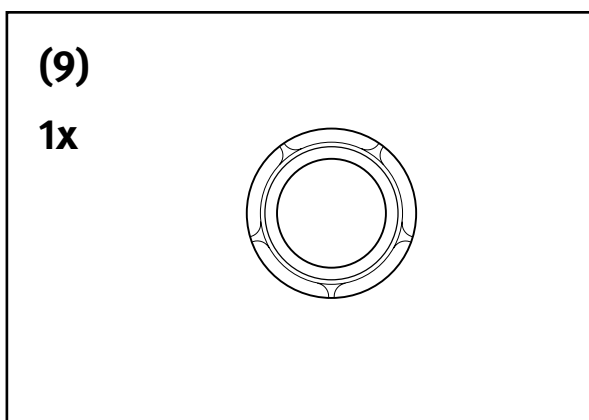

Fig. 9

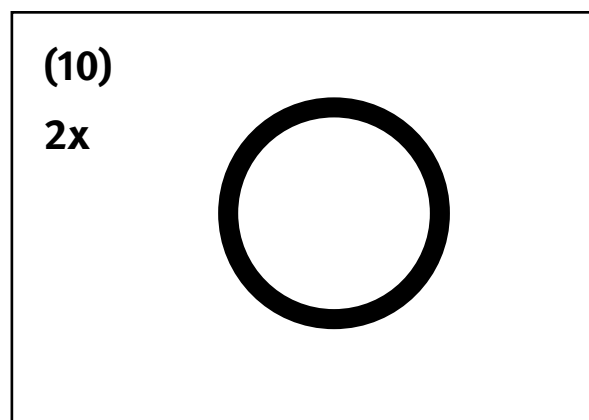

Fig. 10

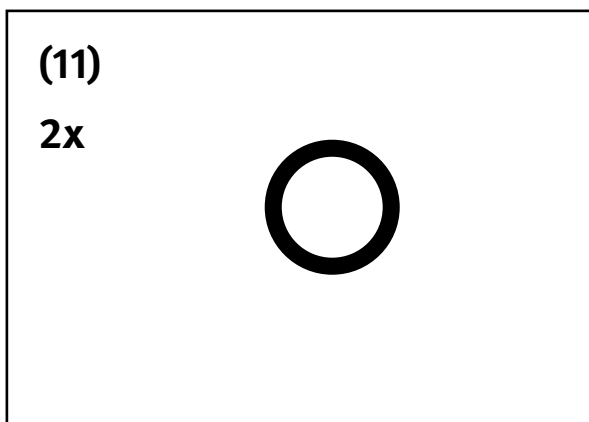

Fig. 11

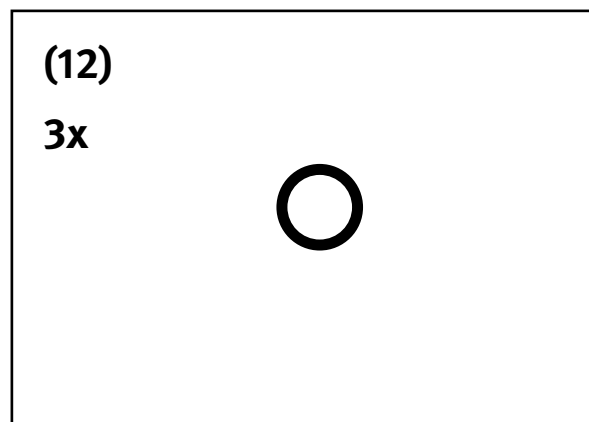

Fig. 12

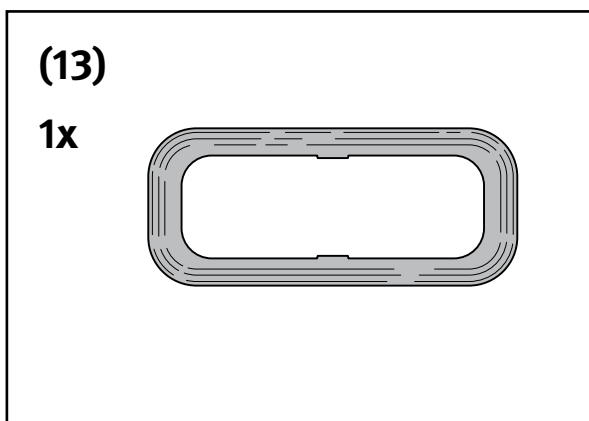
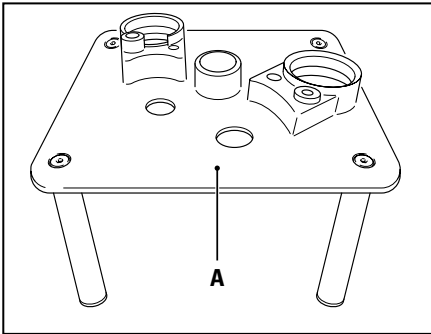

Fig. 13

**Tool set (400 0477 10) for the professional repair of the Ford DPS6 and Renault DC4 transmissions.**



**Assembly table:**

- Table (A) for securing the shafts, gear shift mechanism and controller drums
- For use during disassembly and assembly

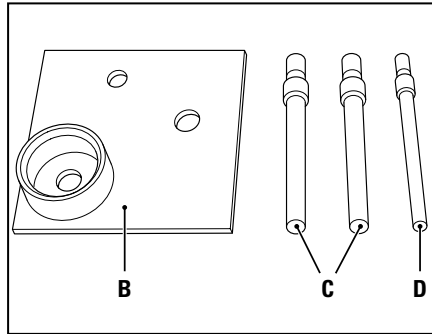

**Shaft holder:**

- Plate (B)
- 2 x guide bolts (C) for output shafts
- 1 x guide bolts (D) for drive shaft

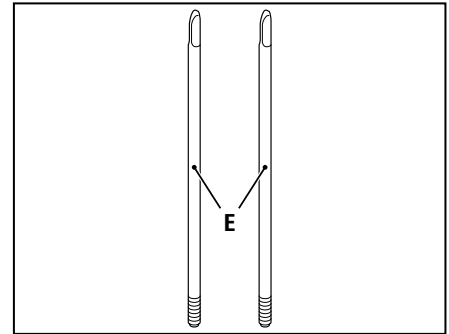

**Guide pins:**

- Guide pins (E) for the holding plates on the output shaft bearings

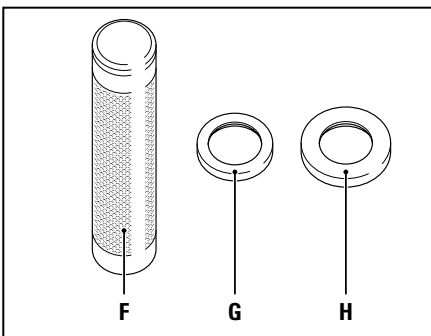

**Assembly tool:**

- Pressure sleeve (F)
- Thrust piece (G) for output shaft bearing and transmission housing
- Thrust piece (H) for drive shaft sealing ring

**Note:**

For disassembly and assembly of the dry double clutch, additional special tools are required, listed below for example:

- LuK 2CT basic tool set (400 0418 10)
- LuK 2CT Ford tool set (400 0427 10)
- LuK 2CT Renault tool set (400 0470 10)

When carrying out any work, country and vehicle manufacturer-specific safety requirements and guidelines must be taken into consideration!

Further information can be found at [www.rexpert.com](http://www.rexpert.com) and in our technical brochures.

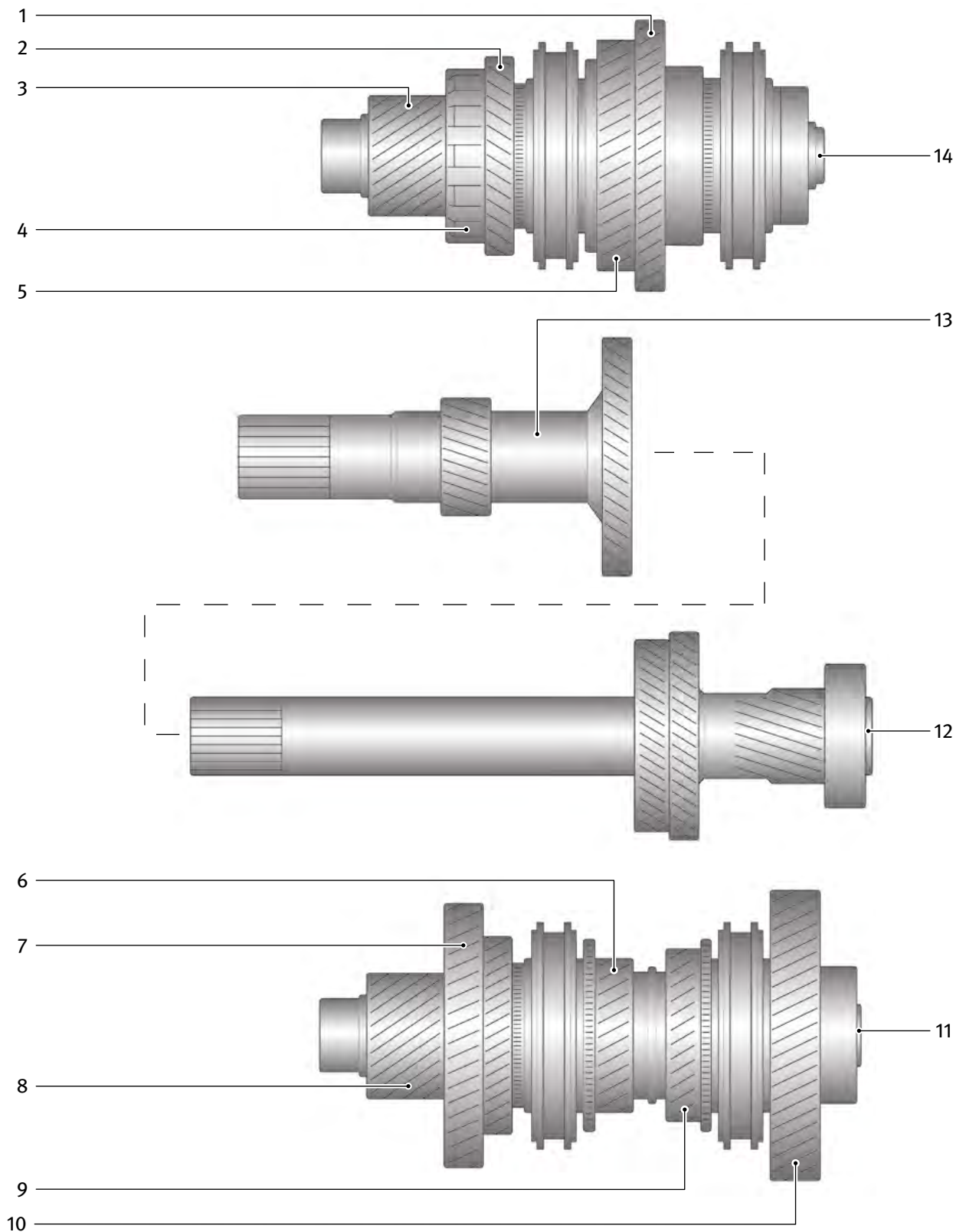

- 1. 3rd gear wheel
- 2. Reverse gear wheel
- 3. Differential gear
- 4. Parking lock gear
- 5. 4th gear wheel
- 6. 6th gear wheel
- 7. 2nd gear wheel

- 8. Differential gear
- 9. 5th gear wheel
- 10. 1st gear wheel
- 11. Output shaft 1
- 12. Drive shaft/solid shaft
- 13. Drive shaft/hollow shaft
- 14. Output shaft 2

- Drain transmission fluid and screw drain plug in again
- Remove the transmission in accordance with the vehicle manufacturer's instructions

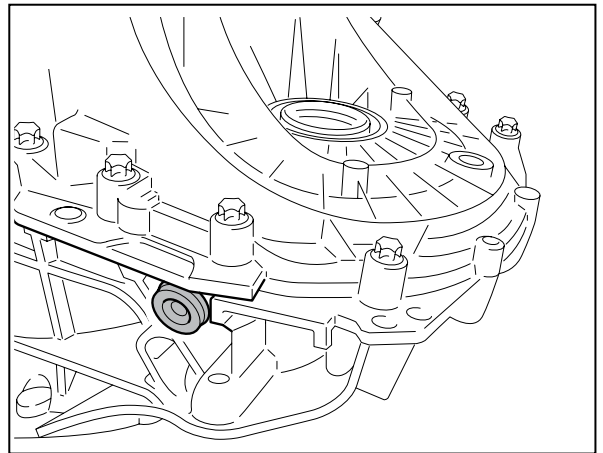

- Remove the double clutch, lever actuators and guide sleeve
- Detailed information can be found at [www.repxpert.com](http://www.repxpert.com) - Installation guides - Product-related installation guides

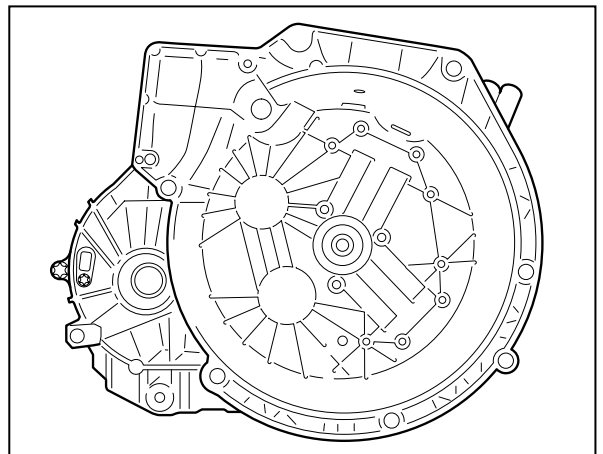

- Remove the control unit

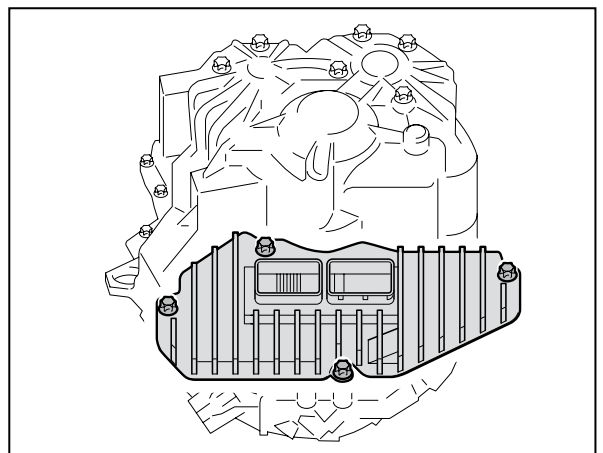



- Place the transmission on a suitable fixture or on a workbench and secure it with the transmission support (KL-0500-802) from LuK 2CT basic tool set (400 0418 10), so that the transmission is stable

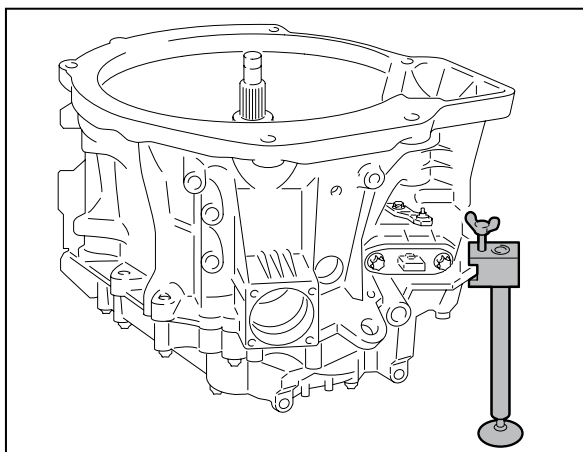

- Remove the parking lock switch

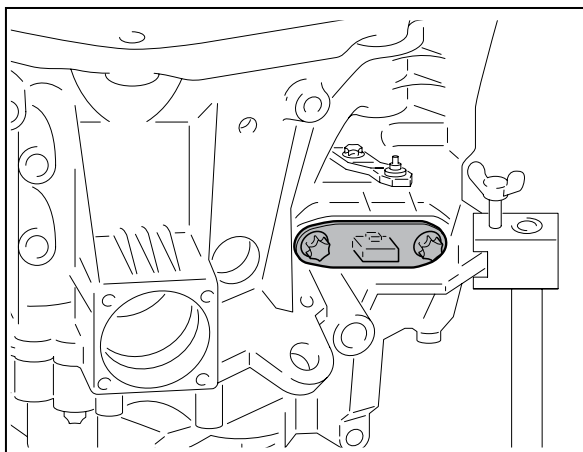

- Remove the speed sensor

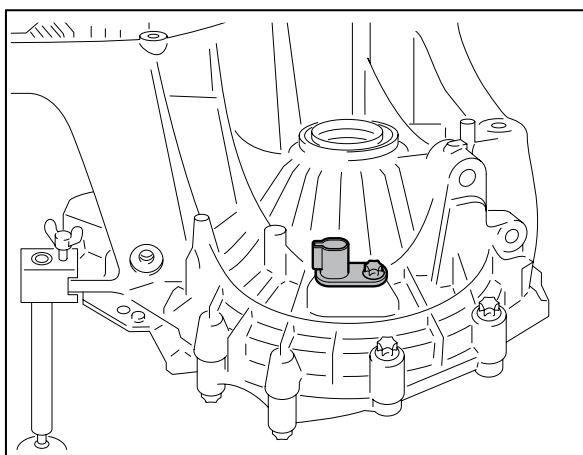

- Remove both speed sensors

**Note:**

If there are levelling discs under the speed sensors, these must not be interchanged or removed.

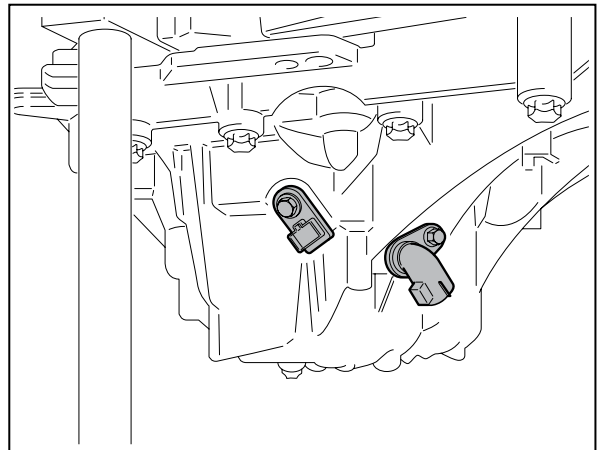

- Drive out the end cover for the retaining bolt of the parking lock lever

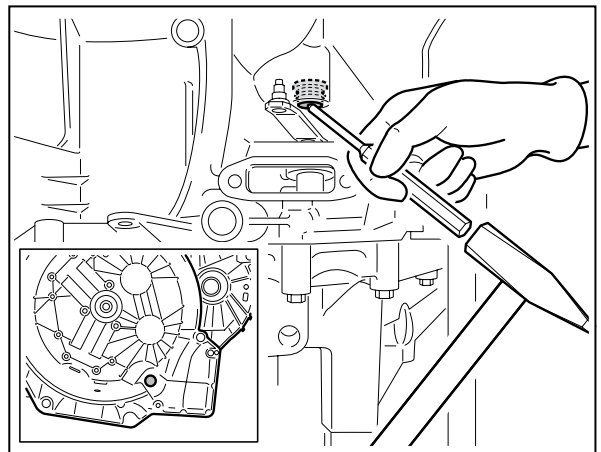

- Remove the bolt and remove the parking lock lever

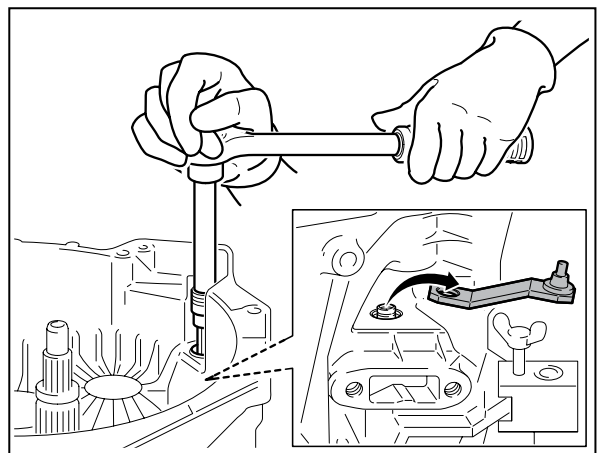

- Remove the housing bolts

**Note:**

Depending on the variant, there are two or three bolts on the differential.

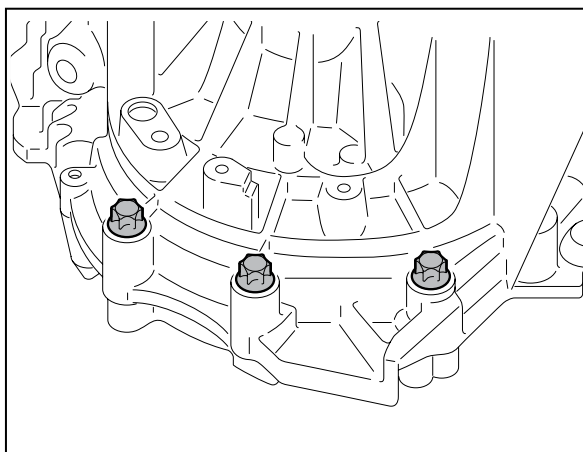

- Remove the housing bolts

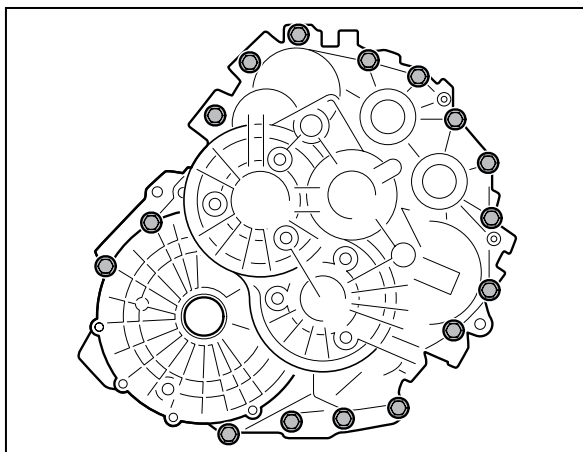

- Remove the drive shaft sealing ring using a suitable tool (e.g. Gedore Automotive KL-0369-59)

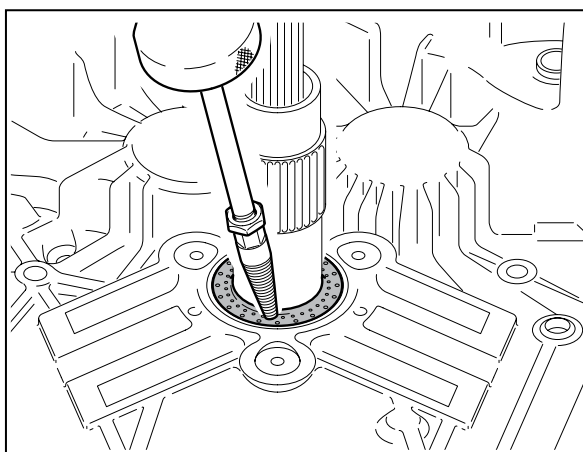

- Remove the snap ring from the drive shaft

**Attention:**

Wear protective goggles!

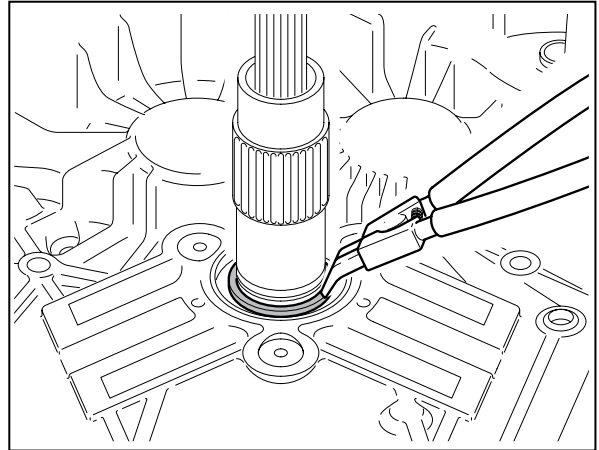

- Remove the clutch housing using the puller from the LuK 2CT basic tool set. To do so:
- Place the support sleeve from LuK 2CT Ford or Renault tool set (KL-0500-8212 or KL-0500-8214) on the drive shaft/hollow shaft
- Mount three threaded pins (KL-0500-6021 or KL-0500-6022 depending on the assembly options) on the bell housing
- Position the threaded pins at an angle of approximately 120° to each other
- Mount the puller (KL-0500-60) on the threaded pins using the knurled screws (KL-0500-6020) so that they are free from tension

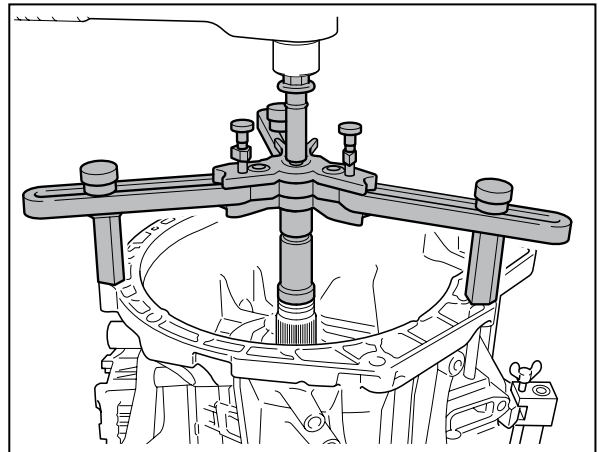

**Note:**

Place the clutch housing to one side, as shown, so that the oil guides are not damaged.

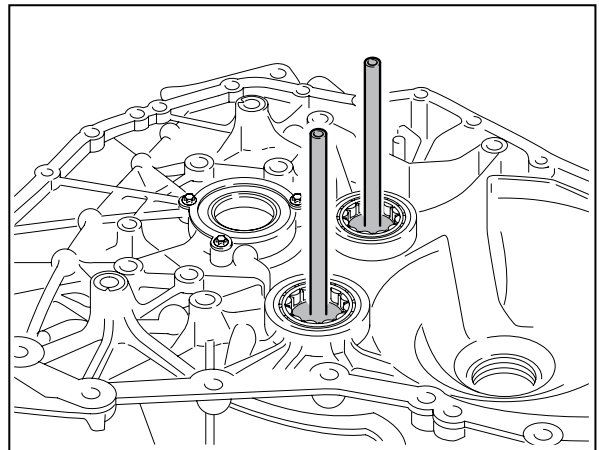

- Remove the large and small toothed gears [1] from the drive for the controller drums, including the bolts
- Remove the differential [2]
- Remove the parking lock pawl and bolts [3]
- Remove the magnet [4]

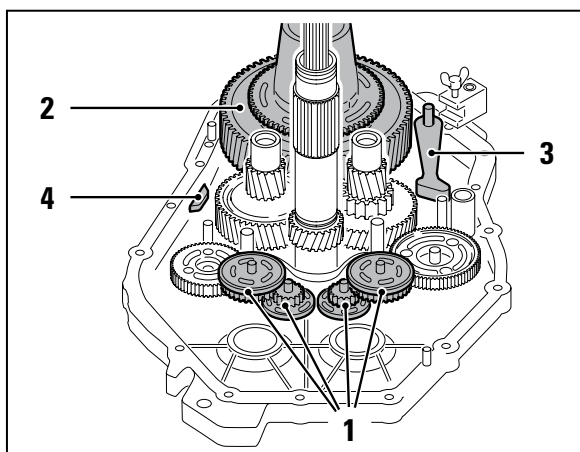

- Position the assembly table (A) from the special tool set (400 0477 10) on the drive shaft
- Ensure that the controller drums and output shafts are correctly positioned in the special tool

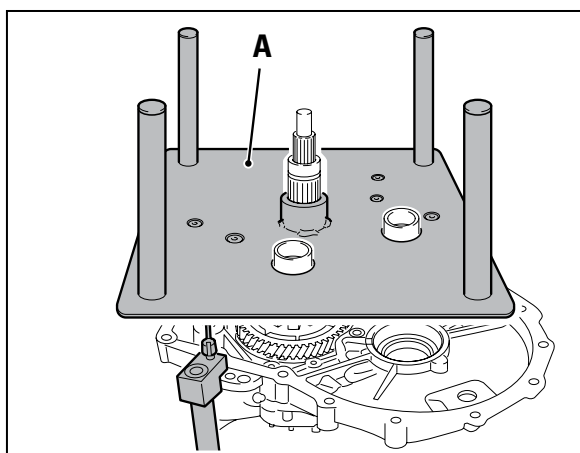

- Set up the assembly table including the transmission
- Remove the transmission support (KL-0500-802)
- Remove the bolts on the holding plates for the output shaft bearing from the transmission housing

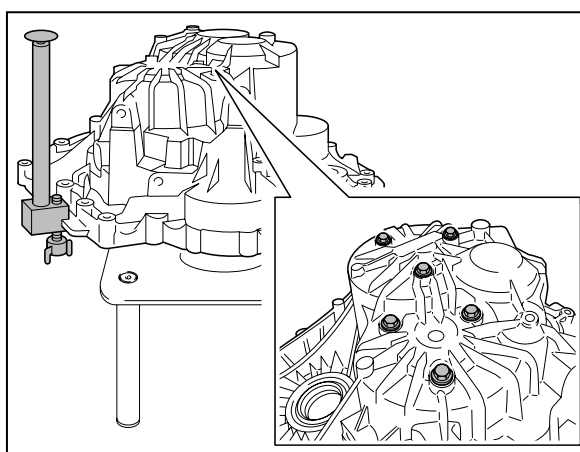

- Lift the transmission housing upwards

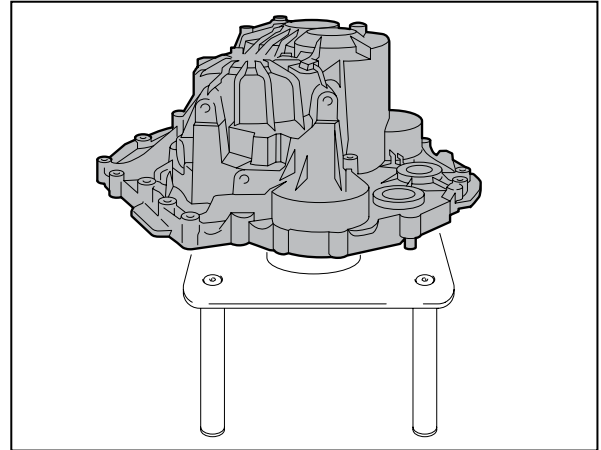

- Remove all four guide bolts on the gear shift forks

**Note:**

Take the different lengths of the guide bolts into account.

On some transmissions, a plastic oil guide is used for better lubrication of the drive shaft! This must be removed and reused in later assembly.

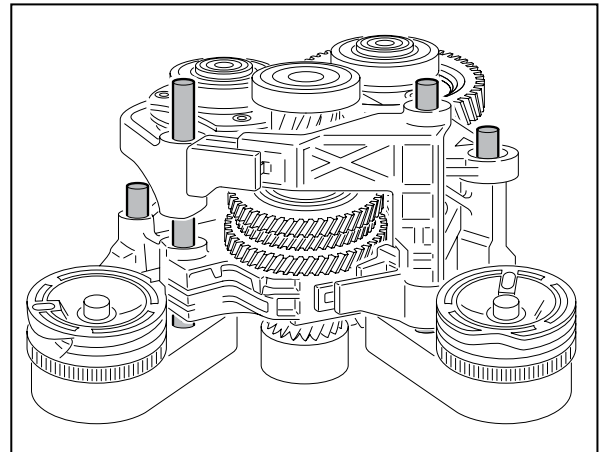

- Remove controller drums [1] and [2]
- Remove the gear shift forks

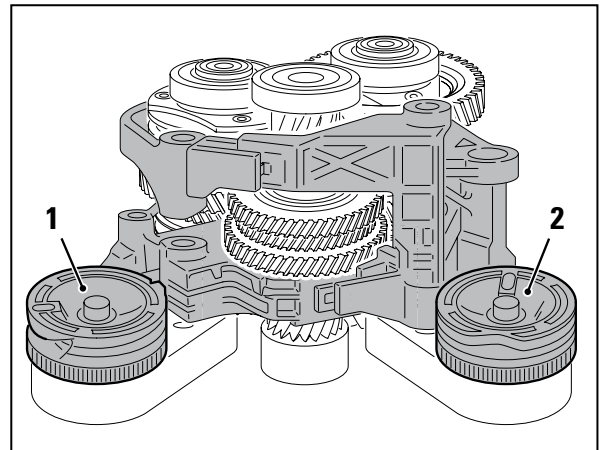

- Screw the guide bolts (C/D) from the special tool set (400 0477 10) into plate (B)
- Insert the mounted tool into the input and output shafts

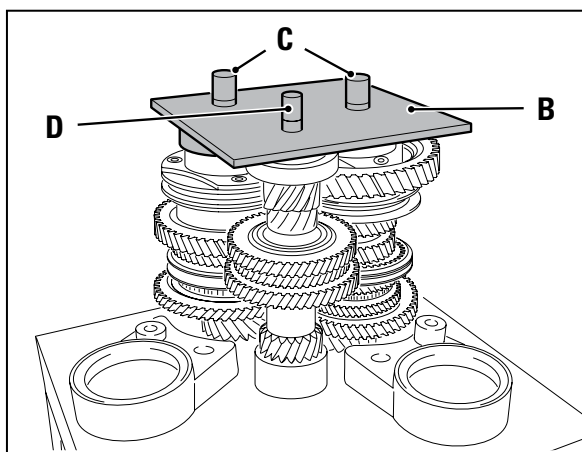

- Place the shaft package and assembly table (A) to the side
- Remove the assembly table

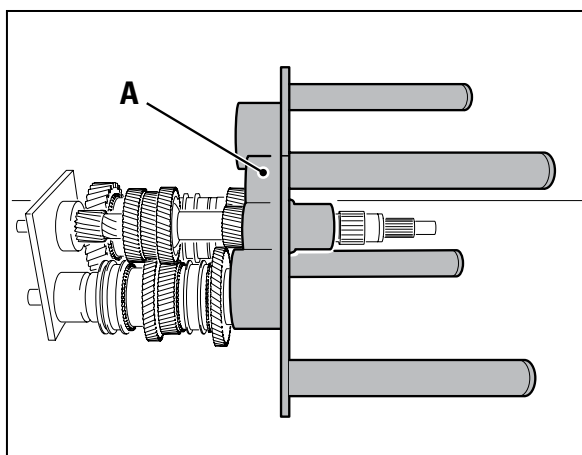

- Separate the shafts by unscrewing the guide bolts (C/D) from plate (B)

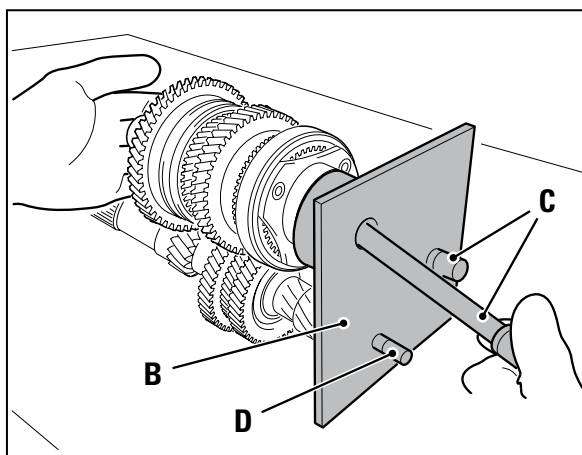

- Separate the hollow shaft [1] from the solid shaft [2]
- Remove the roller and cage assembly [3]

**Note:**

The roller and cage assembly may be located on the solid shaft or in the hollow shaft.

Pay attention to the installation position of the roller and cage assembly.

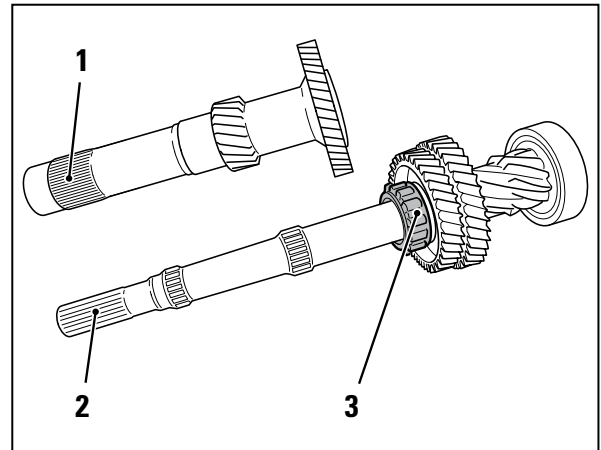

- Pull off the solid shaft bearing

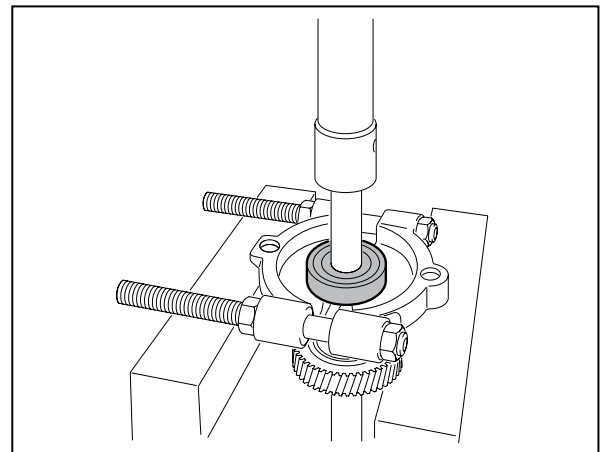

- Press the new bearing (3) onto the solid shaft

**Note:**

Fit the bearing over the bearing inner ring with a suitable sleeve. The new bearing differs only in appearance, complies with the technical specifications and it can be used without restrictions.

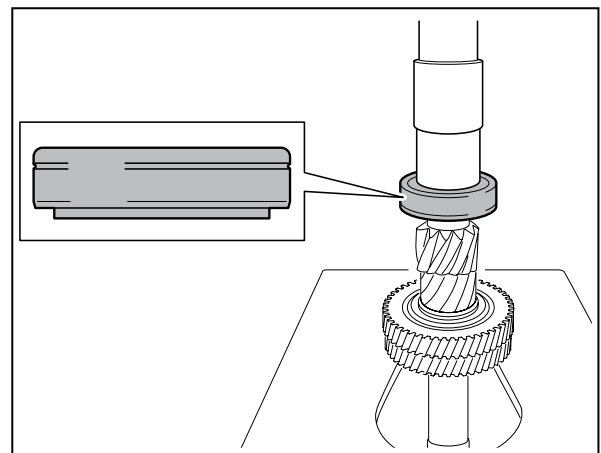



- Replace sealing ring [1] (9) in the hollow shaft
- Assemble the new roller and cage assembly [2] (5) on the solid shaft
- Pay attention to the installation position of the roller and cage assembly

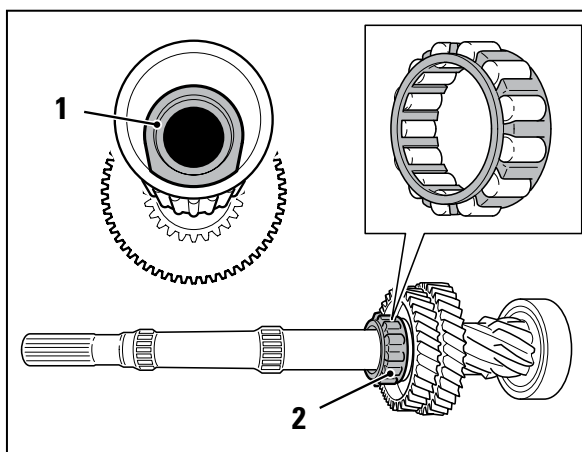

- Remove bolts and remove bearing snap ring in the clutch housing

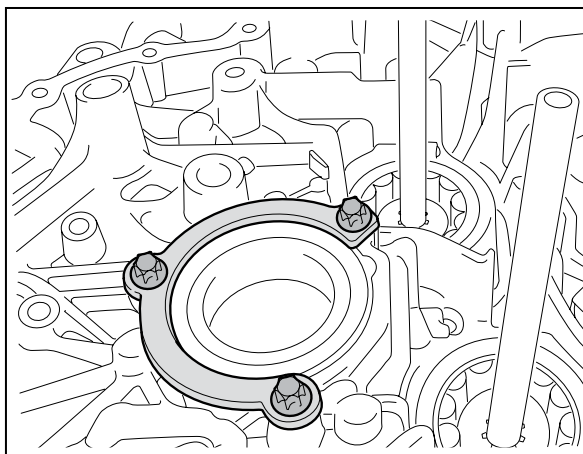

- Pull out the bearing of the drive shaft

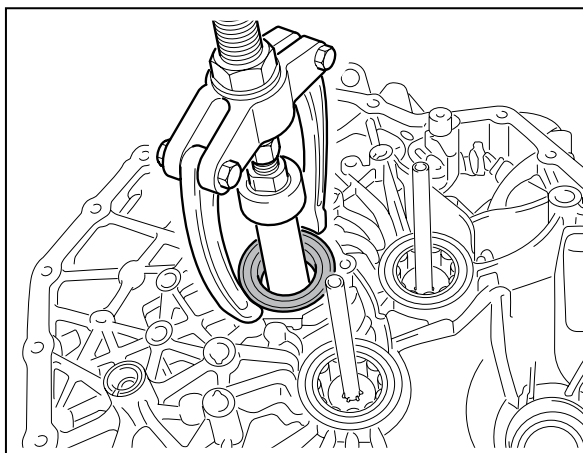

- First separate both output shaft bearing cages and then remove them

**Note:**

Take care not to damage the centrally positioned oil guide.

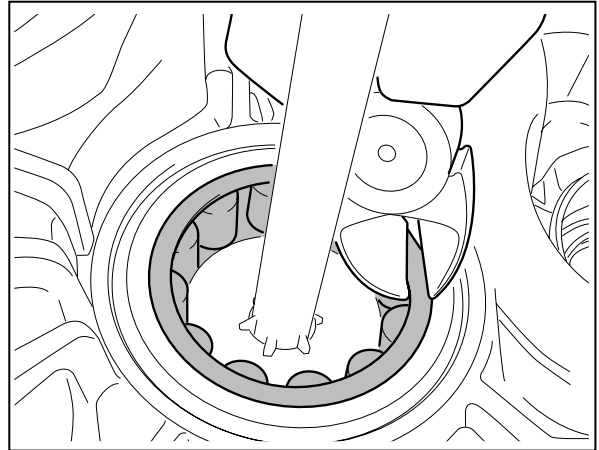

- Remove both bearing outer rings from the output shaft bearings

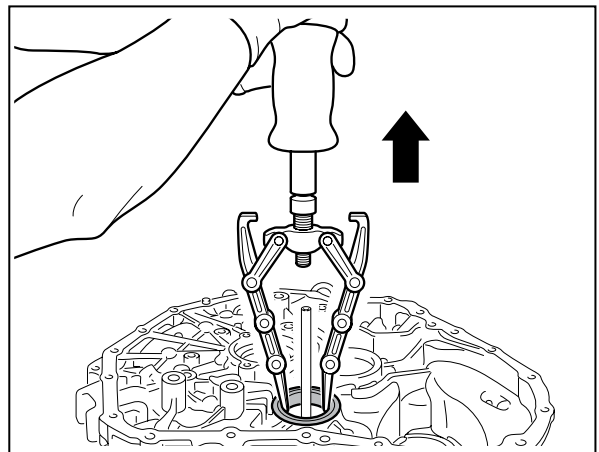

- Replace the flanged shaft sealing ring (7) on the clutch housing

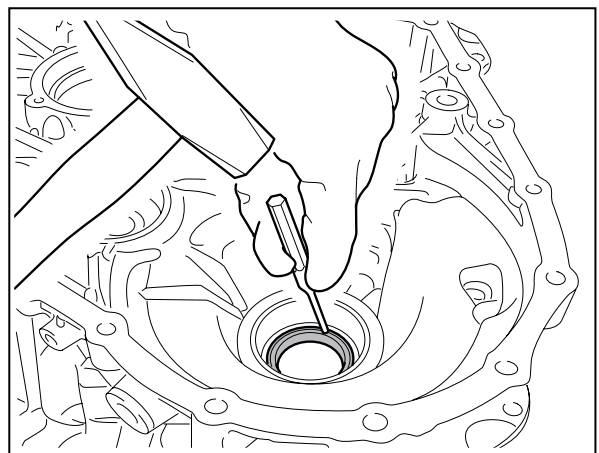

- Press the two new output shaft bearings (4), including the oil guide, into the clutch housing with the pressure sleeve (F) and the thrust piece (G)

**Note:**

Pay attention to the installation position of the bearings.

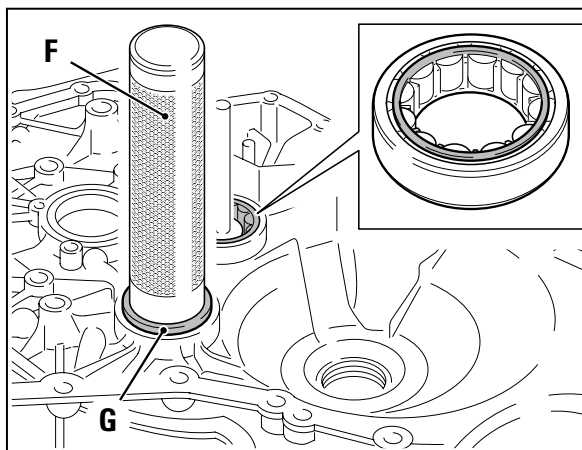

- Press in the new drive shaft bearing (1)

**Note:**

Fit the bearing into the bearing outer ring with a suitable sleeve.

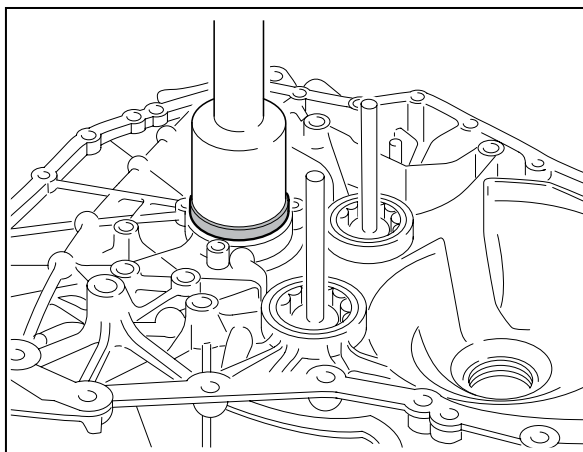

- Fit/install the bearing snap ring  
Tightening torque: 11 Nm

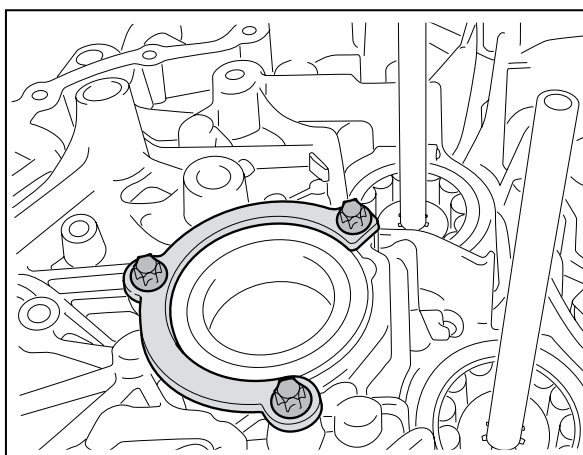

- Replace the flange shaft sealing ring (7) on the transmission housing

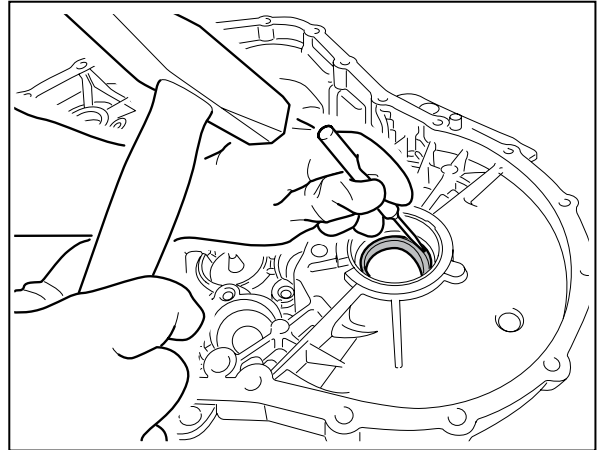

- Remove the snap rings on drive shafts 1 and 2

**Attention:**  
Wear protective goggles!

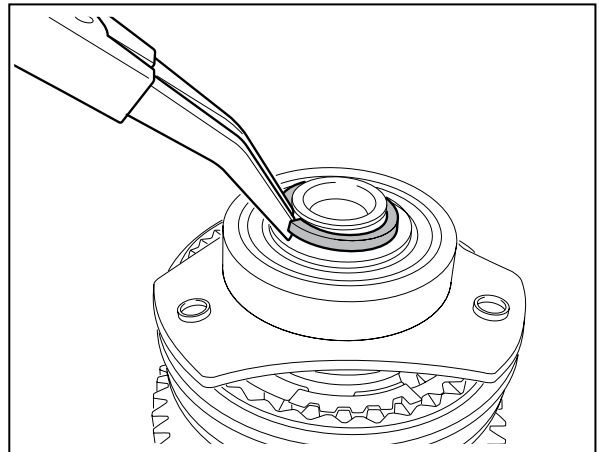

- Remove the output shaft 2 bearing

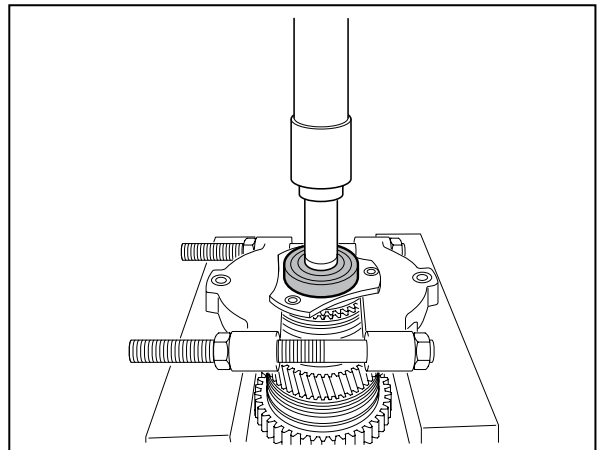

- Press the new output shaft 2 bearing (2)

**Note:**

The shoulder in the outer ring of the bearing must point towards the holding plate.  
Support the shaft package when pressing it onto the parking lock gear.

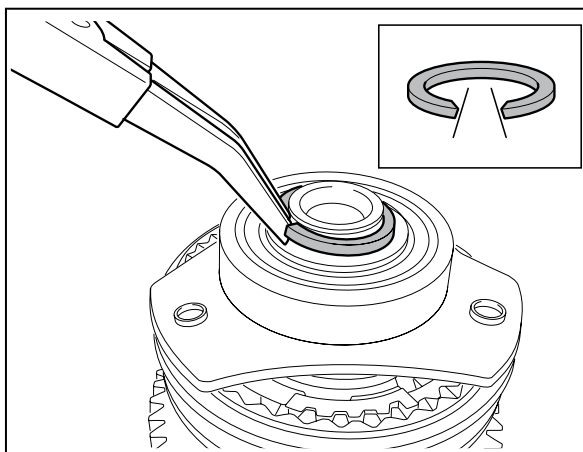

- Force off the output shaft 1 bearing

**Note:**

There is a thrust washer under the bearing.

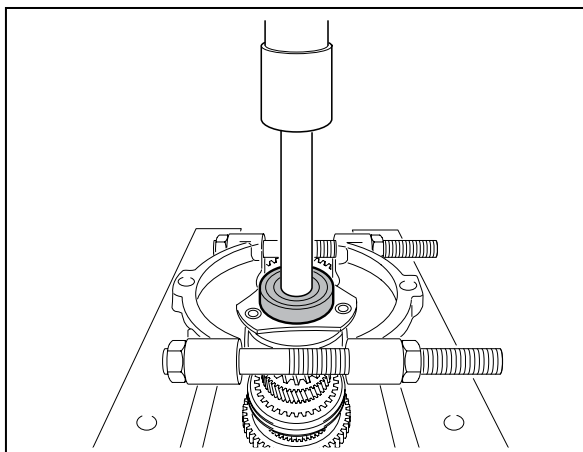

- Press the new output shaft 1 bearing (2)

**Note:**

The shoulder in the outer ring of the bearing must point towards the holding plate.

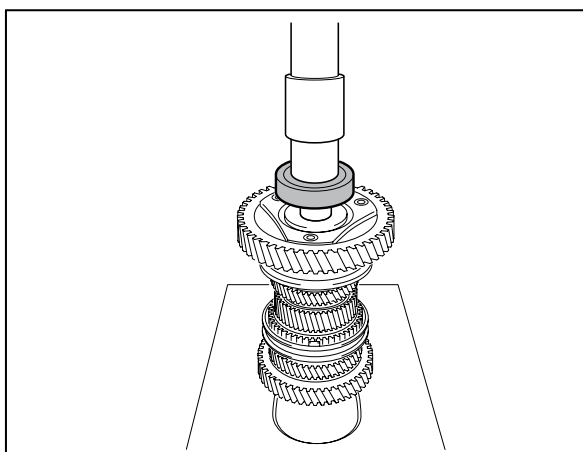

- Fit/install the snap rings on drive shafts 1 and 2

**Note:**

Pay attention to the installation position of the snap rings.

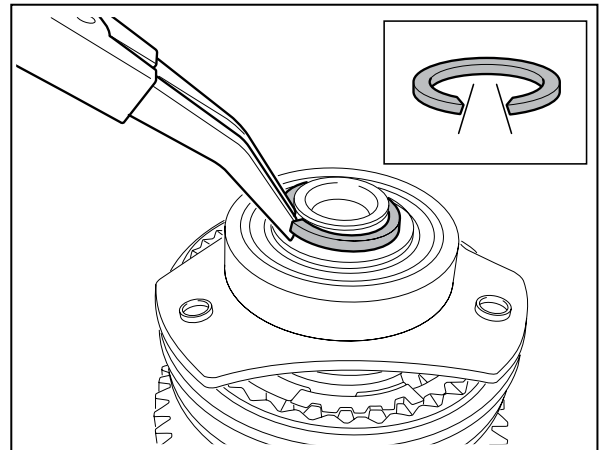

- Mount the input and output shafts using the guide bolts (C/D) on plate (B)

Sequence:

1. Output shaft 2
2. Output shaft 1
3. Drive shaft (hollow and solid shaft)

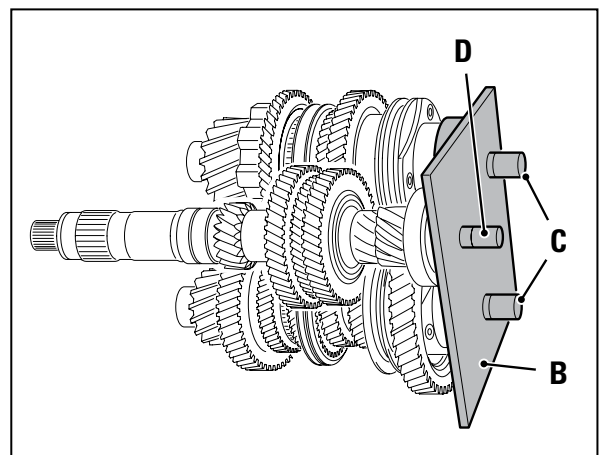

- Position the shaft package on assembly table (A)
- Remove the plate, including the guide bolts, upwards from the drive and output shafts

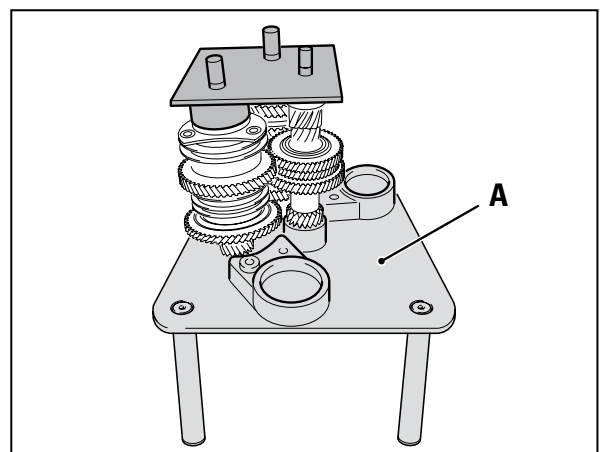

- Install the gear shift rod and the gear shift fork for fourth gear and reverse gear

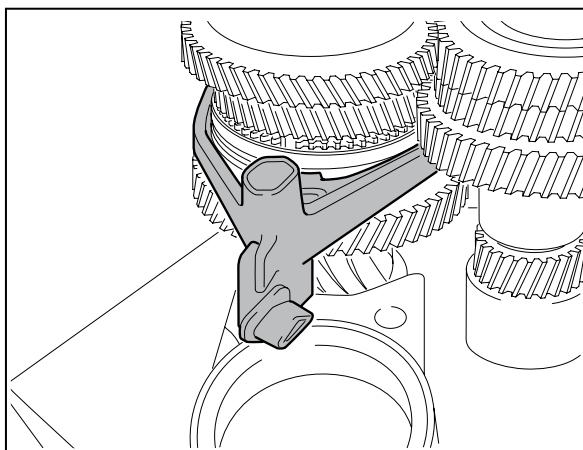

- Install the gear shift fork for second and sixth gear

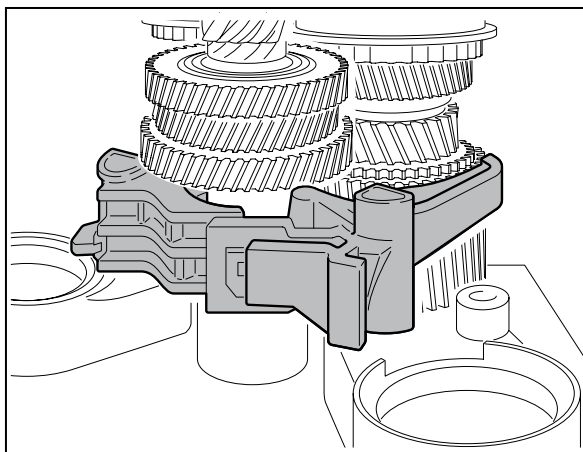

- Insert controller drum 1 and the bolts

**Note:**

Put controller drum 1 in the neutral position.  
The wide opening faces outward.

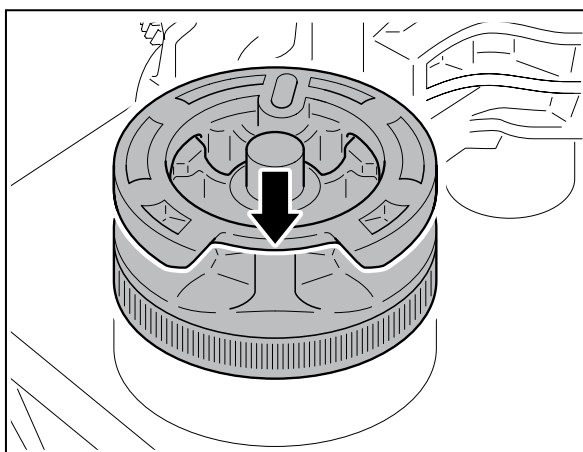

- Install gear selector fork for third gear, controller drum 2 and the bolts

**Note:**

- Put controller drum 2 in the neutral position.
- The wide opening faces outward.

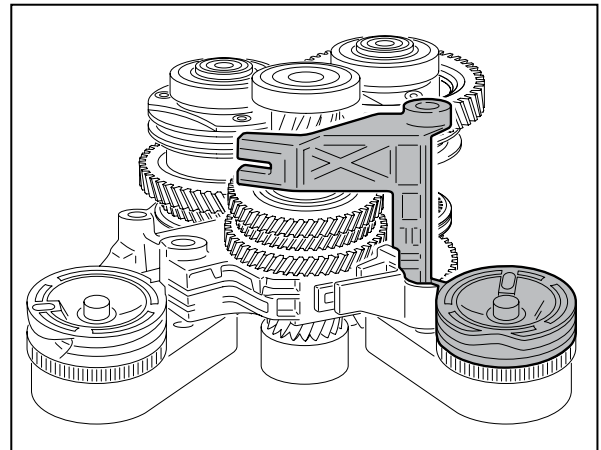

- Assemble the gear selector fork for first and fifth gear

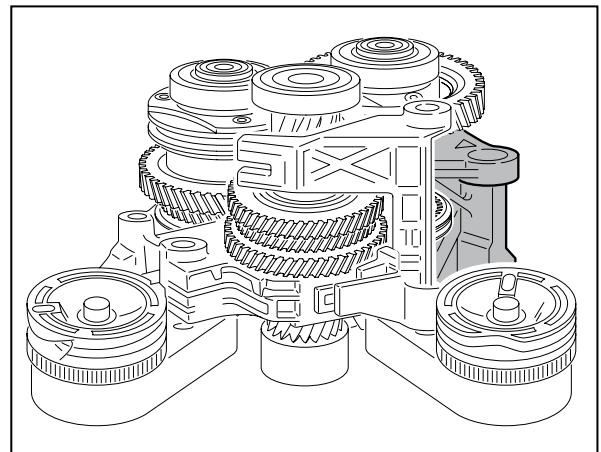

- Install the gear selector fork for third gear

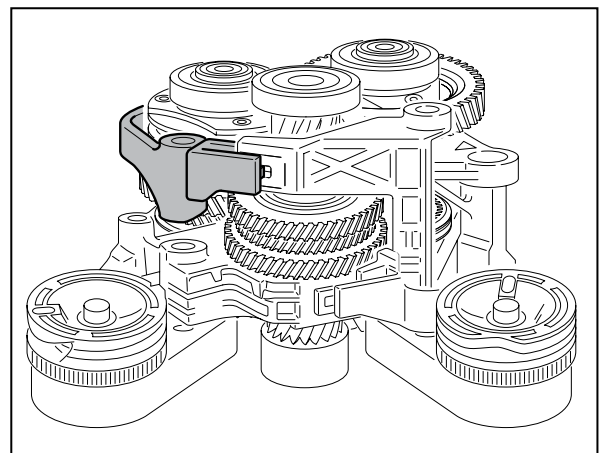



- Install all four guide shafts on the gear shift forks

**Note:**

Take the different lengths of the guide bolts into account.

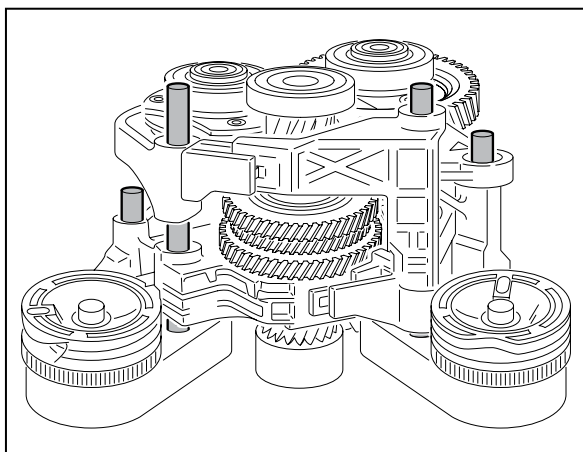

- Screw in the guide pins (E)

**Note:**

On some transmissions, a plastic oil guide is used for better lubrication of the drive shaft.

If an oil guide has been disassembled, it must be re-inserted during this work step.

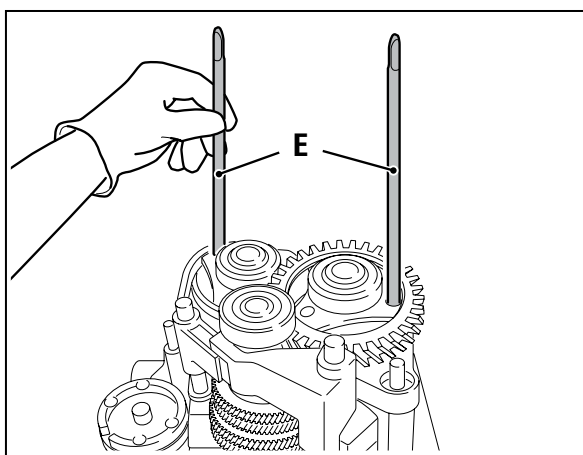

- Install the transmission housing

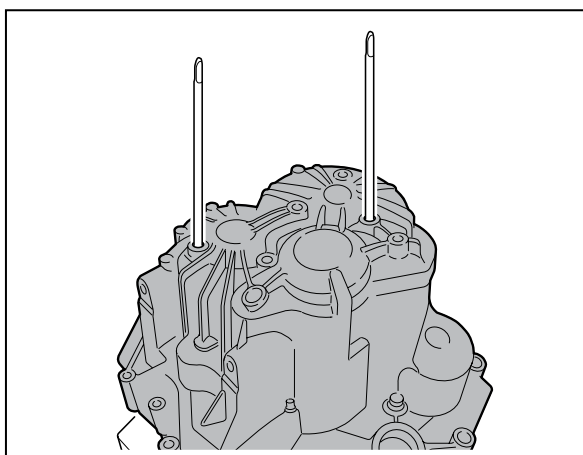

- Remove the guide pins
- Secure the holding plates of the output shaft bearings to the transmission housing in two steps
  - tightening torque:
  - Step 1: 10 Nm
  - Step 2: 32 Nm

**Note:**

To make it easier to install the bolts, pull the holding plates upwards using the guide pins.

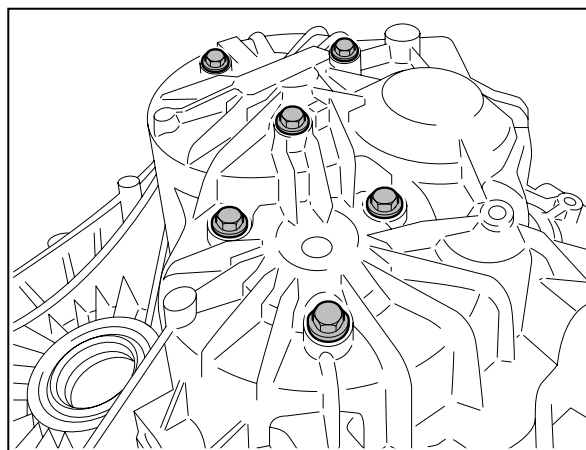

- Attach the transmission support from LuK 2CT basic tool set (400 0418 10)
- Turn over the transmission half with assembly table (A)
- Lift the assembly table (A) upwards to remove it

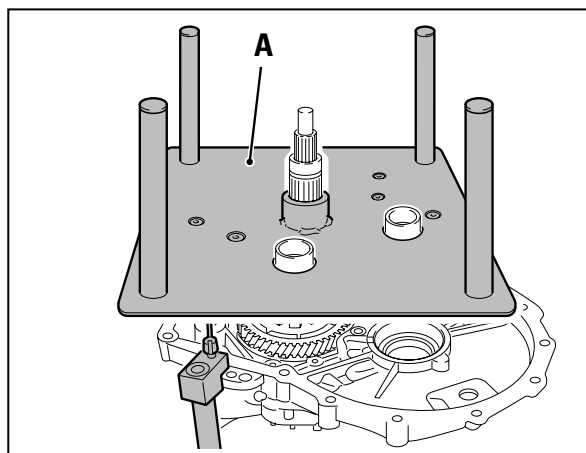

- Insert the large and small toothed gears [1] on the drive for the controller drums, including the shafts
- Install the differential [2]
- Install the parking lock pawl and bolts [3]
- Insert the magnet [4]

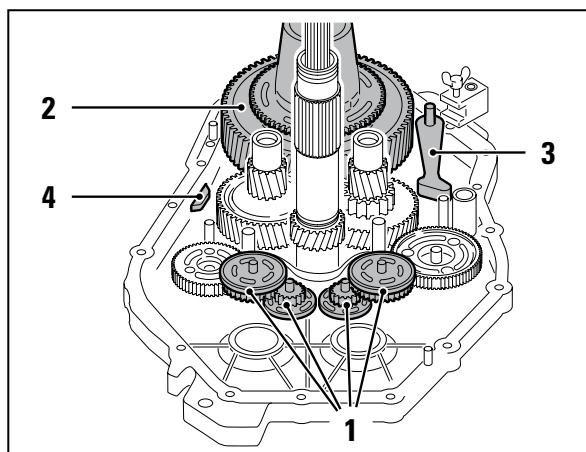

- Replace the shaft sealing ring (8) on the parking lock lever in the clutch housing

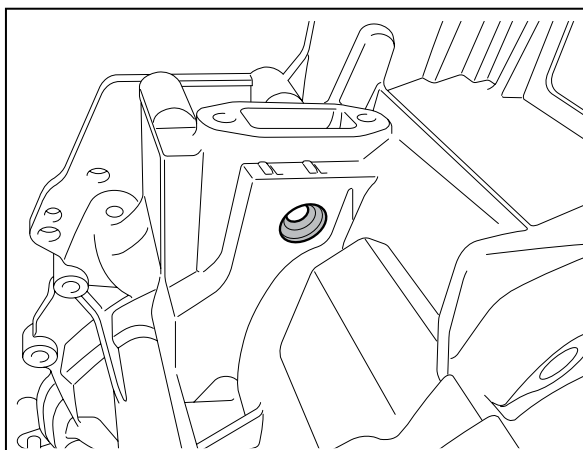

- Remove bolt [2] in the clutch housing
- Drive out the detent [1] by driving it inwards using a suitable tool

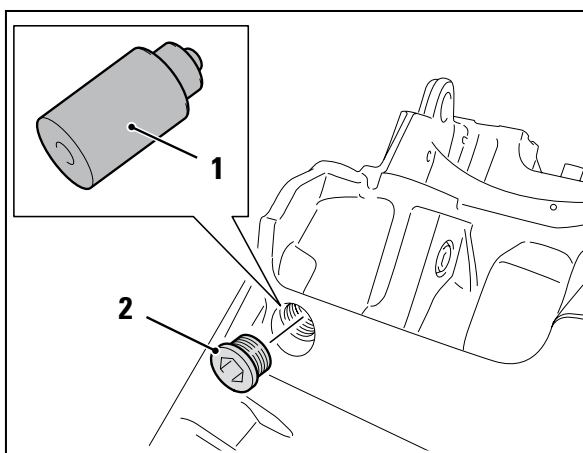

- Apply sealing compound evenly, as shown, to the transmission housing

Ford specification: WSK-M2G348-A5

Alternative: e.g. Loctite Gasket Maker 518

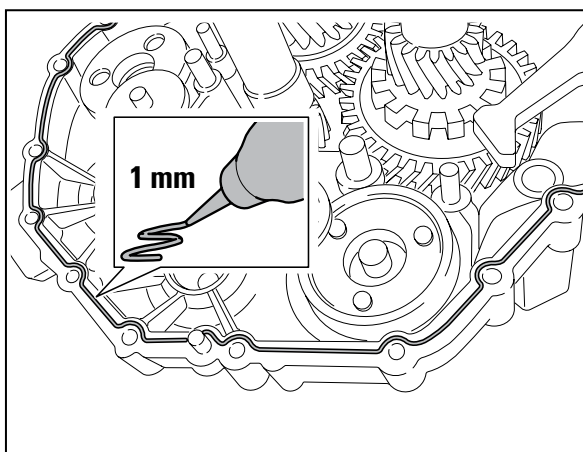

- Check that the parking lock lever and shaft are positioned correctly

**Note:**

The parking lock lever must be in the engaged position. This position must not be changed until the detent has been assembled.

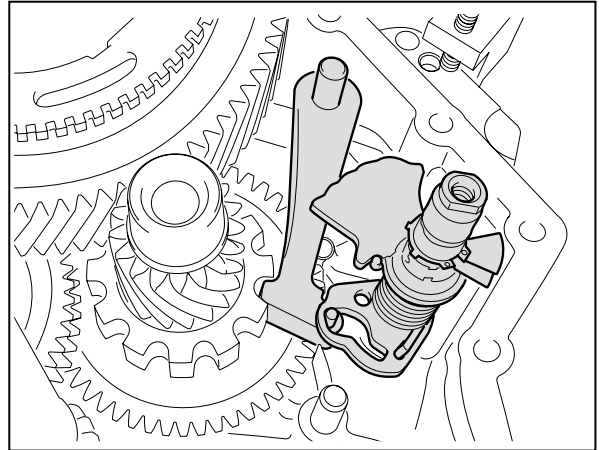

- Gently heat the bearing inner ring of the drive shaft to make it easier to assemble the clutch housing

**Note:**

Do not damage the seal while heating.

- Fit the clutch housing
- To join the housing halves more easily, the guide pins (E) can be screwed into the threads for the housing bolts

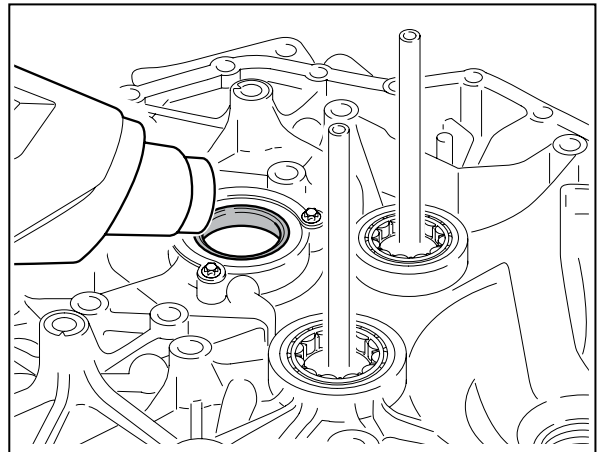

- Join the clutch housing and the transmission housing using the pressure sleeve (F) and the thrust piece (G) over the bearing inner ring of the drive shaft

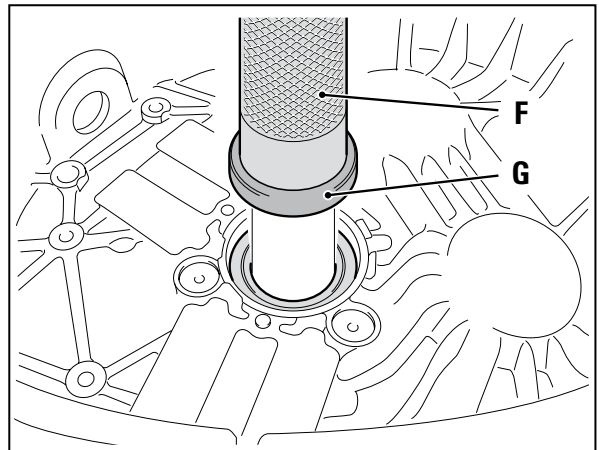

- First tighten the housing bolts by hand

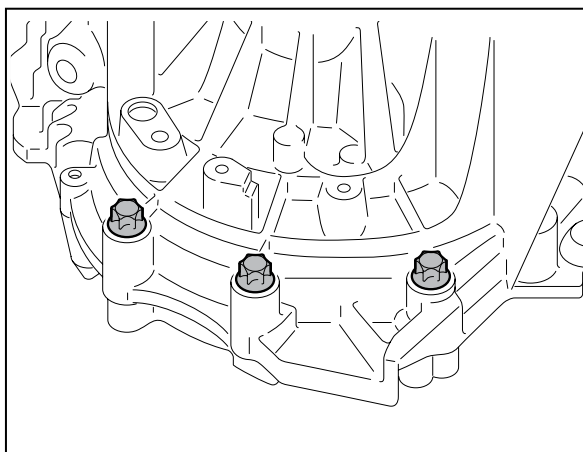

- Tighten all the housing bolts crosswise and evenly  
Tightening torque: 27 Nm

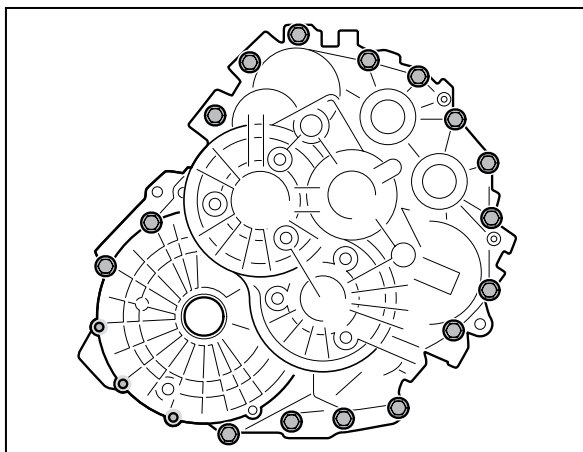

- Use a suitable tool to fit the detent [1] into the clutch housing until four thread turns are visible
- Tighten bolt [2]  
Tightening torque: 46 Nm

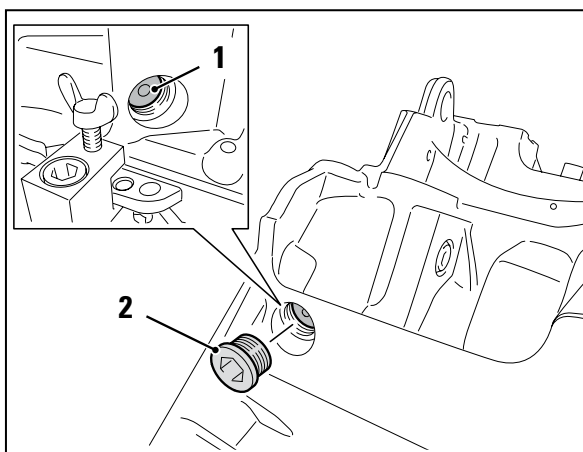

- Assemble parking lock lever and bolt  
Tightening torque: 26 Nm
- Insert end cover

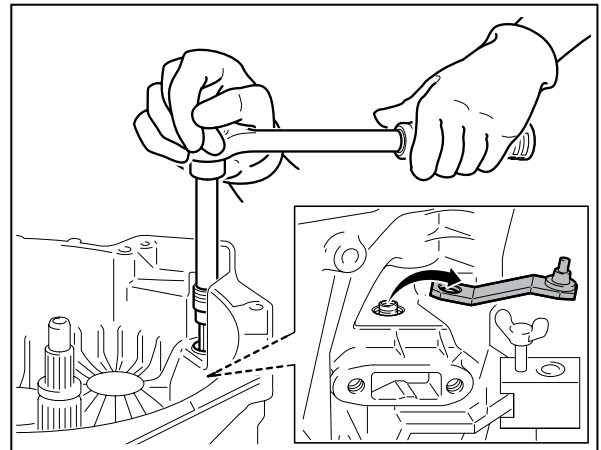

- Fit the snap ring on the drive shaft

**Note:**

Pay attention to the installation position of the snap ring.

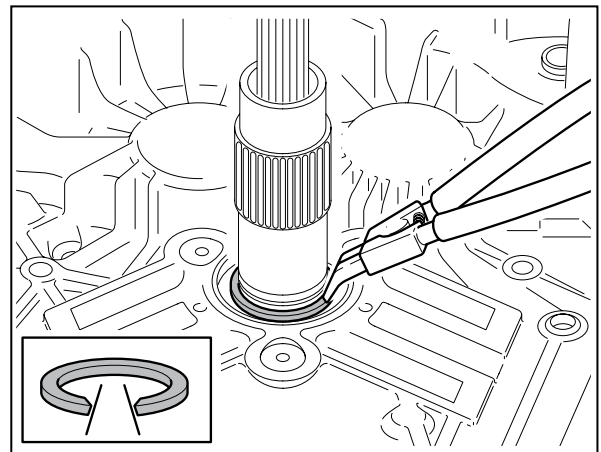

- Insert the new sealing ring (6) with the pressure sleeve (F) and the thrust piece (H)

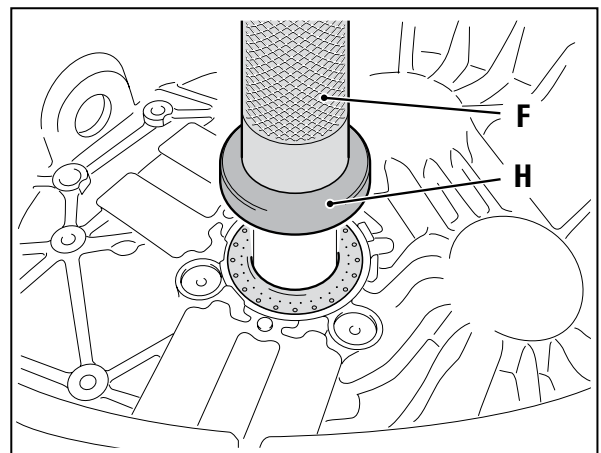

- Install the parking lock switch with a new seal (13)

Tightening torque: 10 Nm

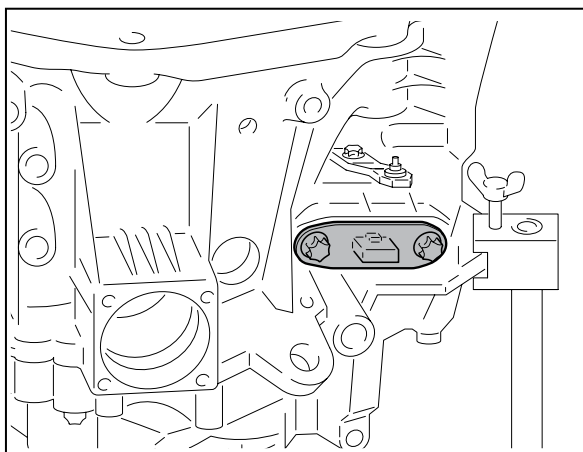

- Install O-rings (12) for both speed sensors
- Assemble the speed sensors

Tightening torque: 10 Nm

**Note:**

If there were any levelling discs under the speed sensors, these must not be interchanged or removed.

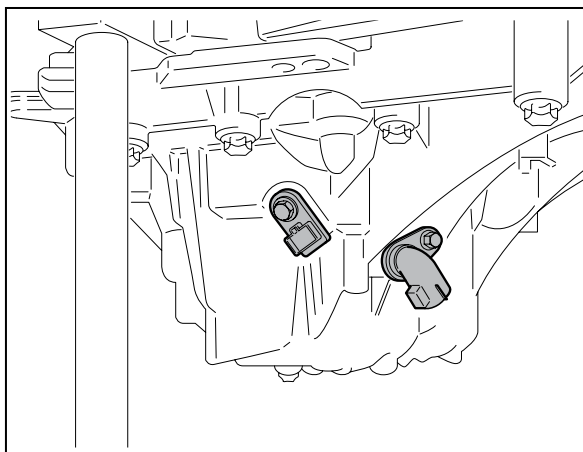

- Install the O-ring (12)
- Assemble the speed sensor
- Tightening torque: 10 Nm
- Remove the transmission support

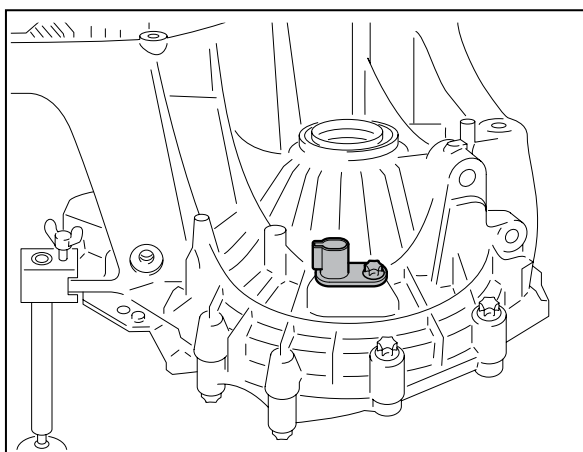

- Replace the two O-rings (10) for the control unit

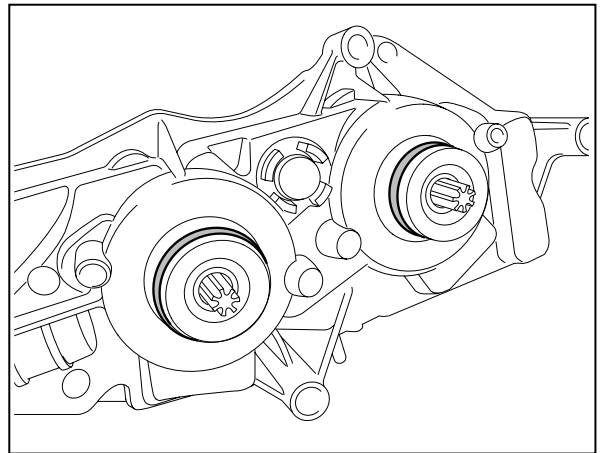

- Install the control unit  
Tightening torque: 27 Nm

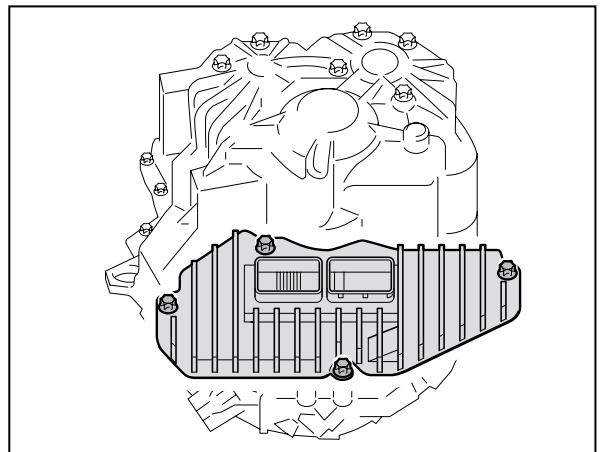

- Assemble the guide sleeve, lever actuators and double clutch
- Install the transmission according to vehicle manufacturer's specifications
- Replace the O-rings on the oil drain and oil filler plug
- Fill the transmission in accordance with the vehicle manufacturer's specifications

**Note:**

Finally, complete the basic adjustment of the clutch and transmission system using a suitable diagnostic tool











**More garage knowledge:**  
[www.rexpert.com](http://www.rexpert.com)